

living
b.p.c
bonprix collection

Art. Nr. 947512

LKZ 641164

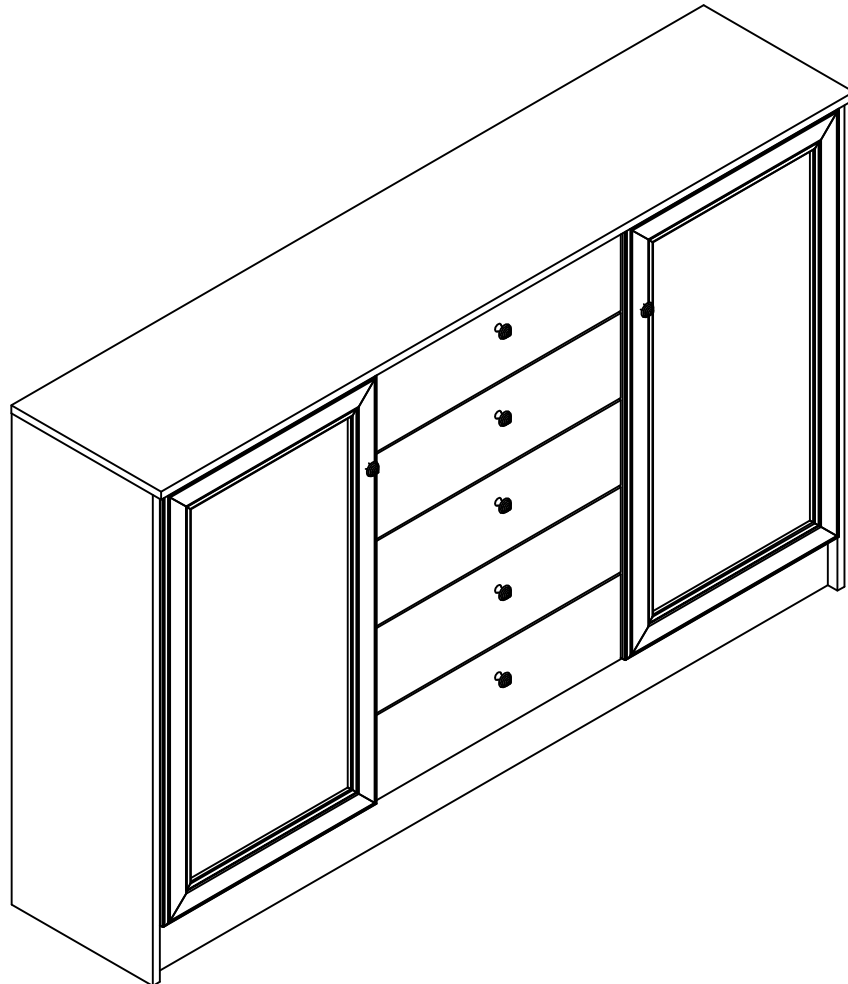

- | | |
|---|-------------------------------------|
| (D) Montageanleitung | (GB) Assembly instructions |
| (FR) Notice de montage | (IT) Istruzioni di montaggio |
| (NL) Handleiding voor de montage | (PL) Instrukcja montazu |
| (CZ) Montážní návod | (SK) Návod na montáž |
| (HU) Szerelési útmutató | (RO) Instrucțiuni de montaj |
| (TR) Montaj talimati | (RU) Инструкция по монтажу |

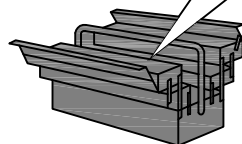
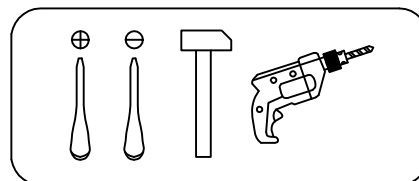
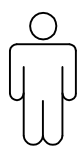

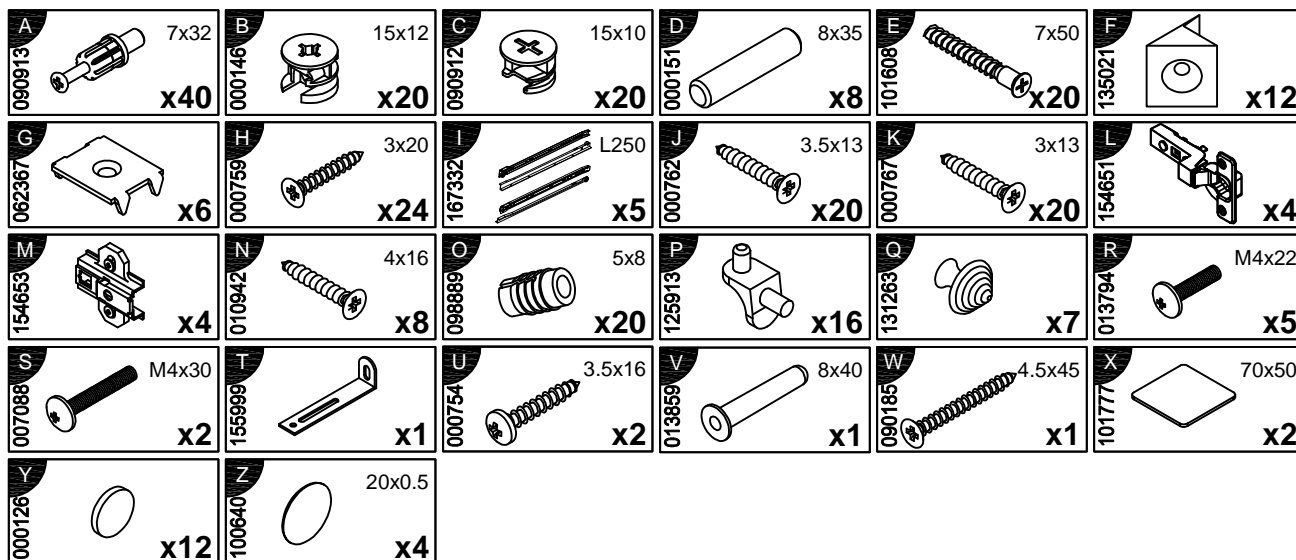

N	Size/MaB (mm)	Qty	✓	N	Size/MaB (mm)	Qty	✓
1	965x320x16	1		13	870x492x3	2	
2	965x320x16	1		14	505x247x3	5	
3	1536x100x16	1		15	250x118x12	5	
4	556x167x16	5		16	250x118x12	5	
5	849x279x16	1		17	495x118x12	5	
6	849x279x16	1					
7	1536x280x16	1					
8	1570x340x16	1					
9	480x278x16	4					
10	852x484x28	1					
11	852x484x28	1					
12	870x558x3	1					

Service - Dienstverlening - Serwis - Servis - Сервисная служба



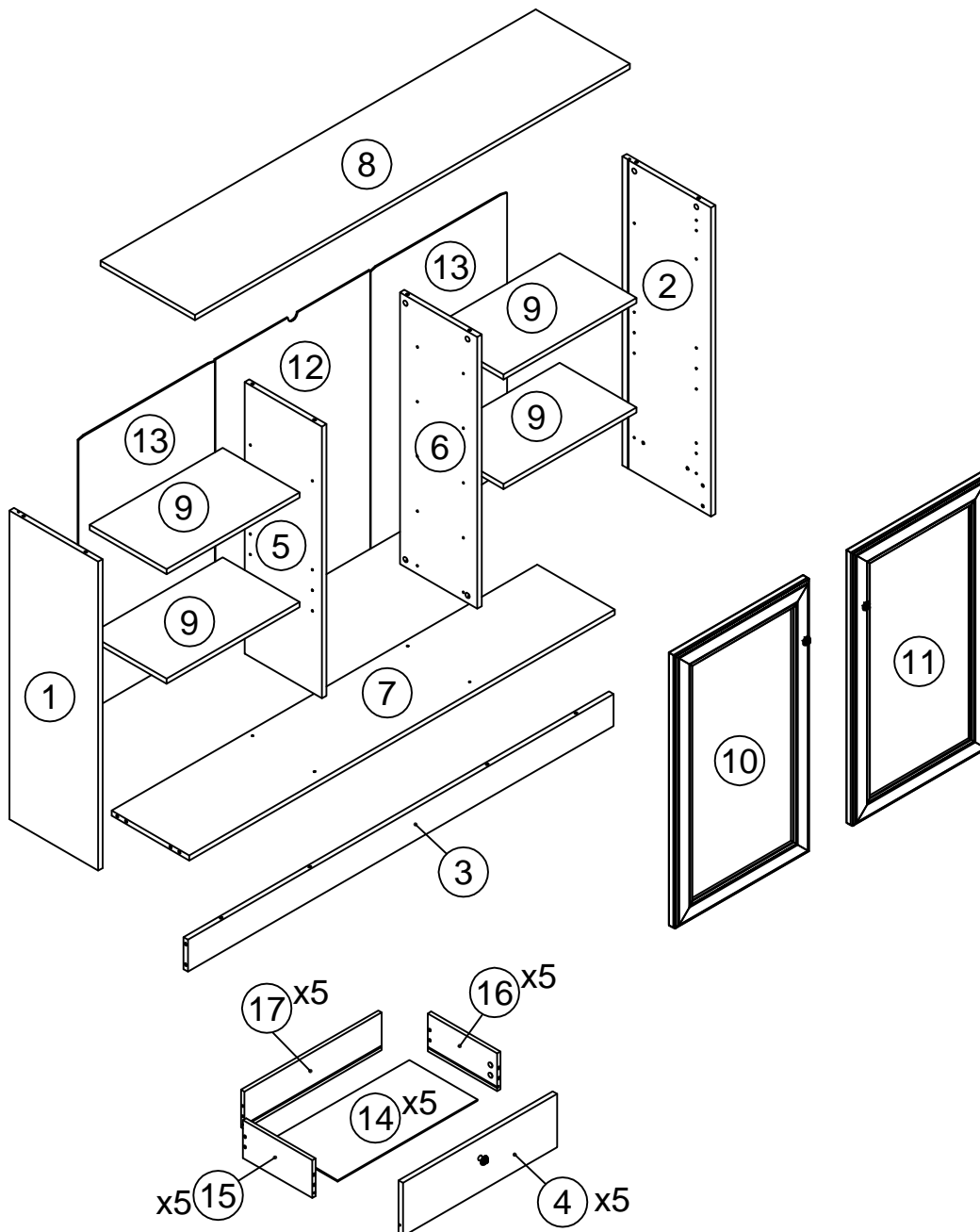
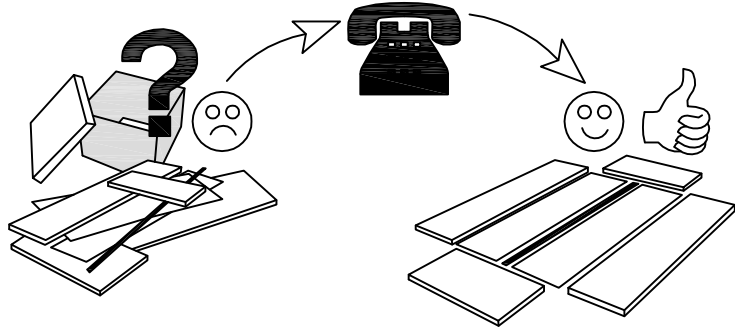
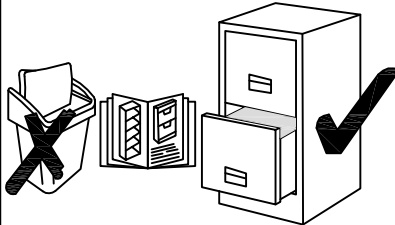

Name - Naam - Nazwa - Isim - Название

Nr. - No. - Номер

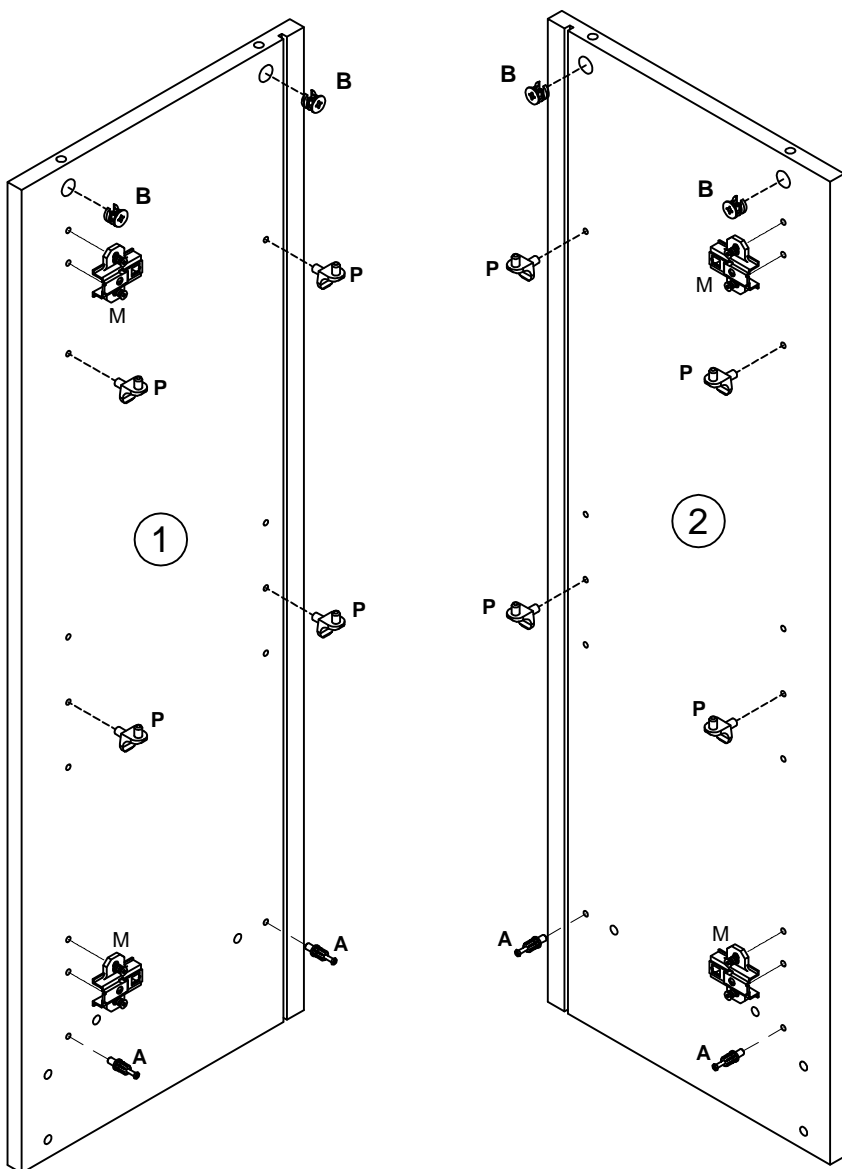
Тур - Туре - Тір - Тип



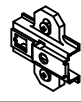



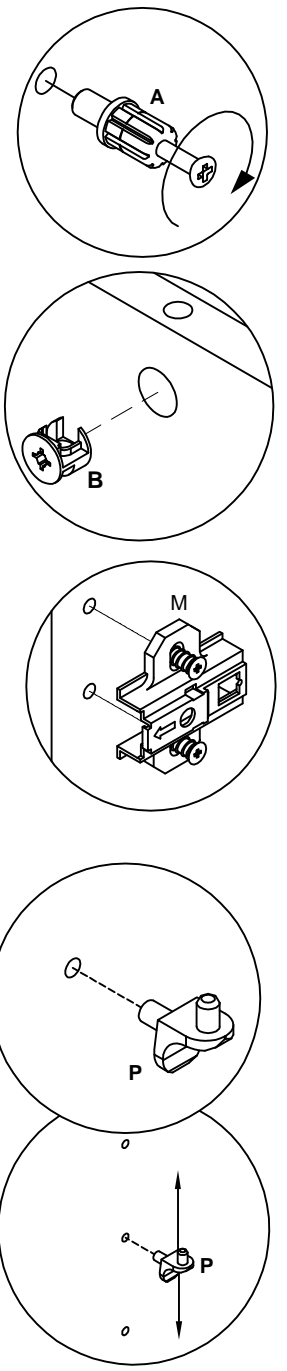

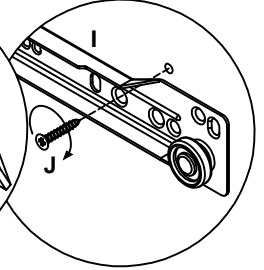
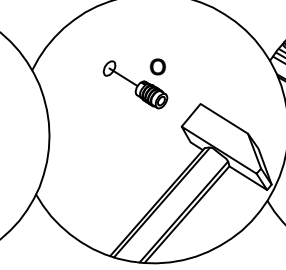
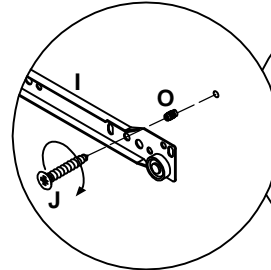
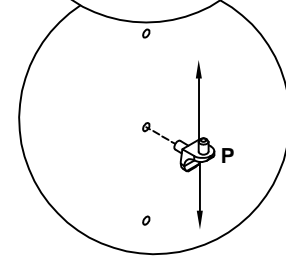
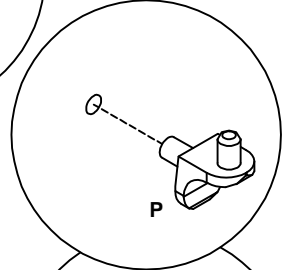
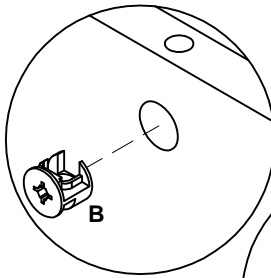
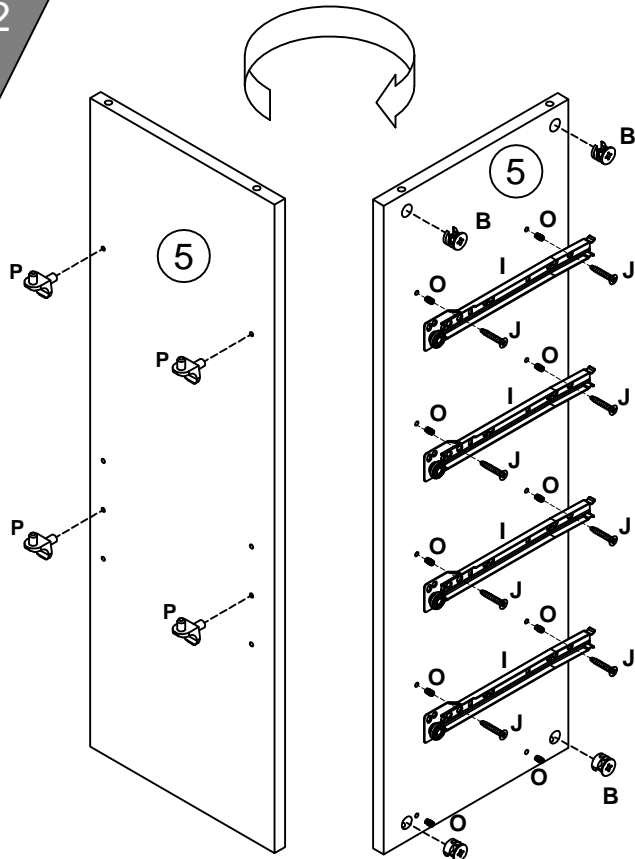

A 090913		7x32 x4
B 000146		15x12 x4
M 154653		x4
P 125913		x8









2

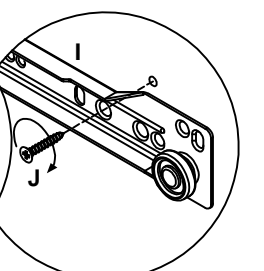
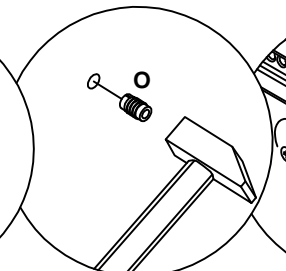
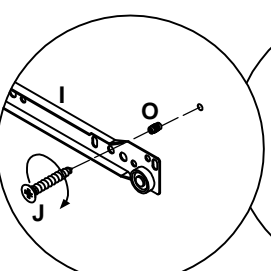
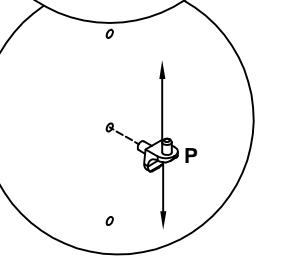
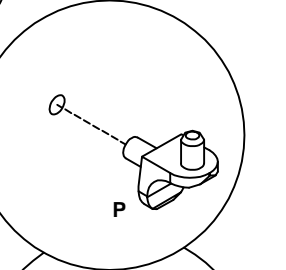
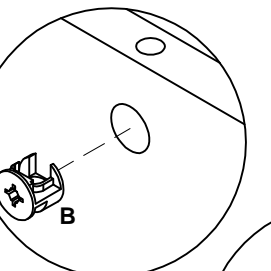
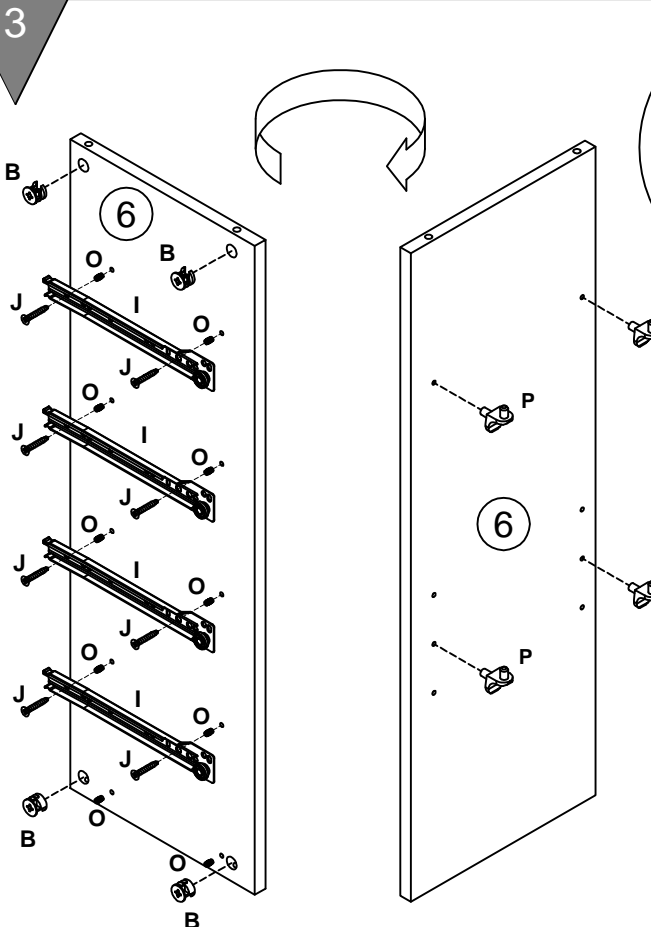

- 000146**  15x12 **x4**
- 167332**  L250 **x4**
- 000762**  3.5x13 **x8**
- 098889**  5x8 **x10**
- 125913**  **x4**



3

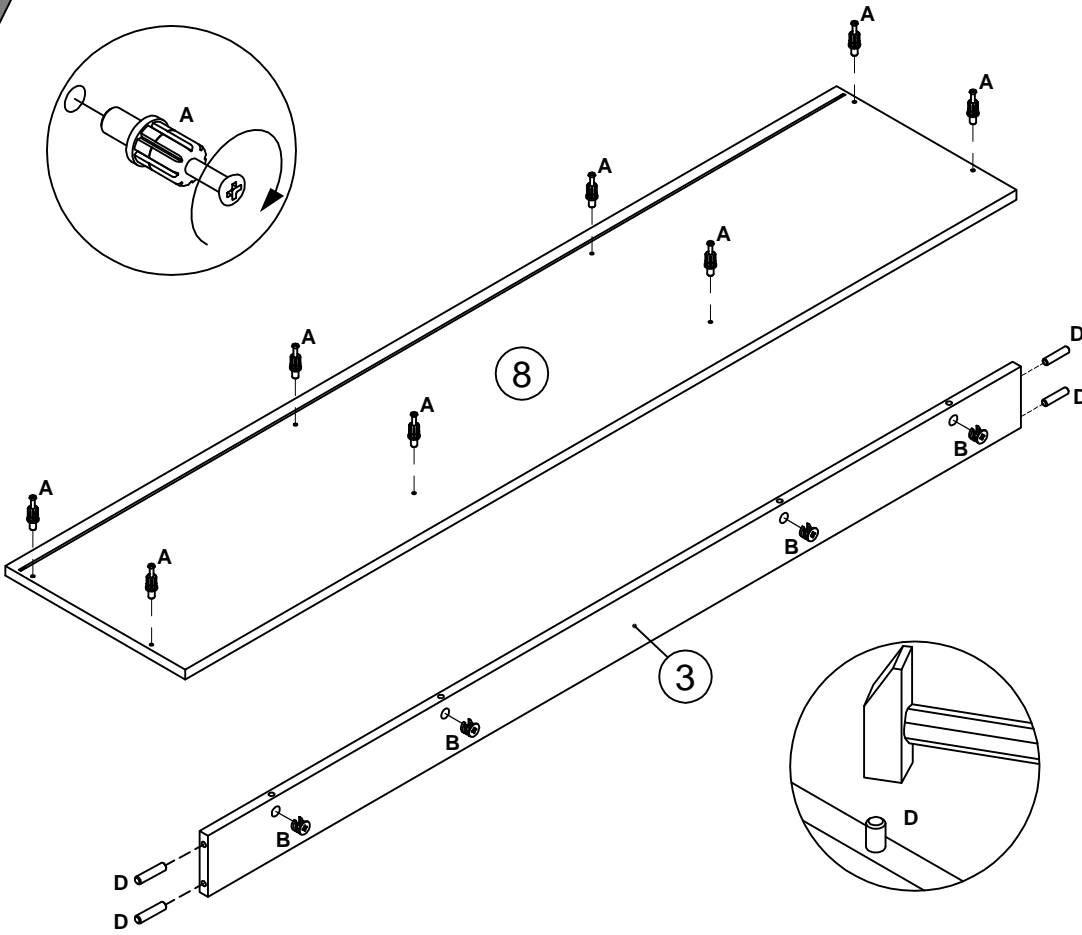

- 000146**  15x12 **x4**
- 167332**  L250 **x4**
- 000762**  3.5x13 **x8**
- 098889**  5x8 **x10**
- 125913**  **x4**

4



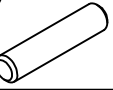

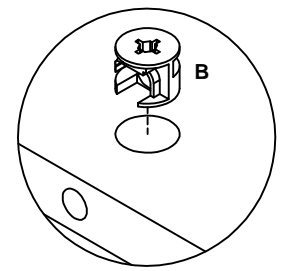
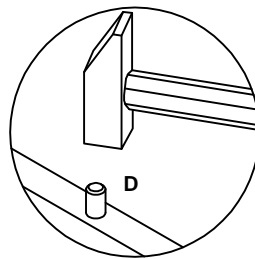
A		7x32
		x8
B		15x12
		x4
D		8x35
		x4

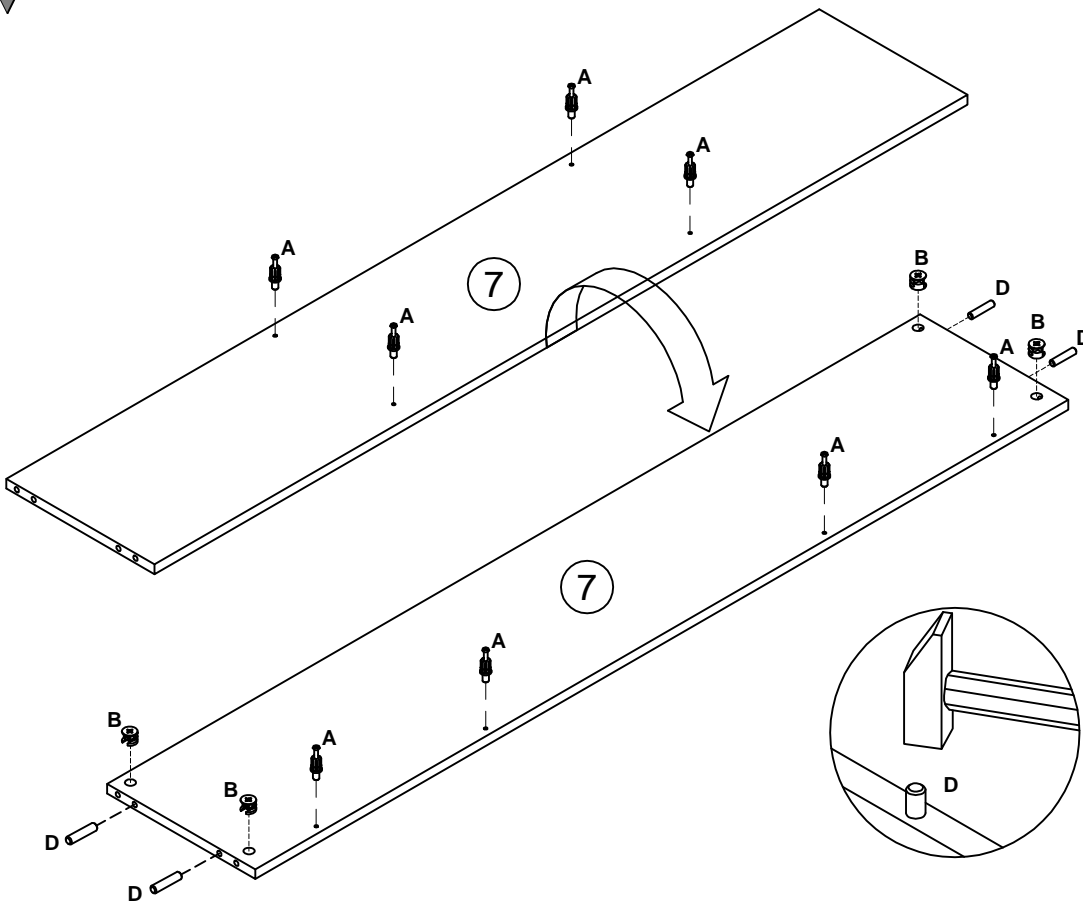

5

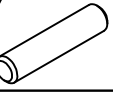

A		7x32
		x8
B		15x12
		x4
D		8x35
		x4

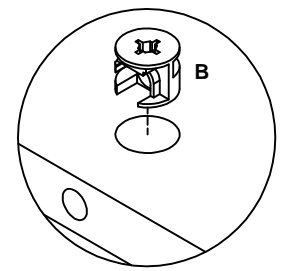
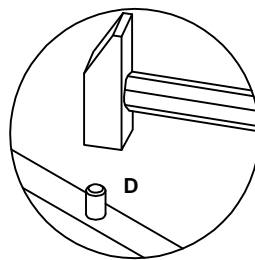
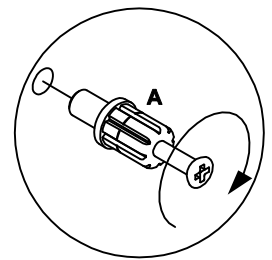

6



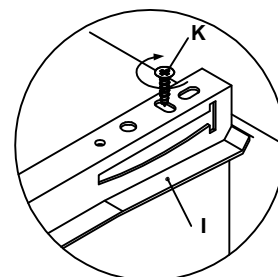
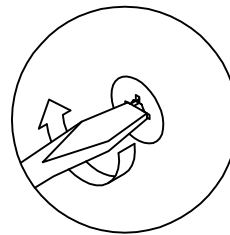
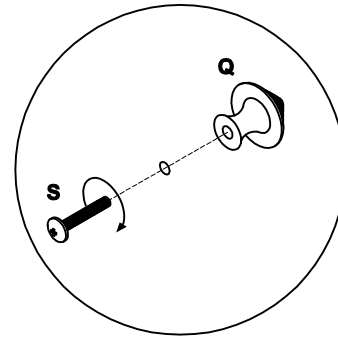
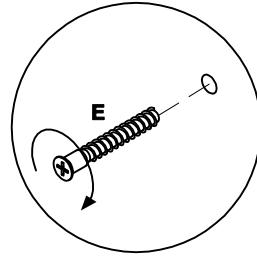
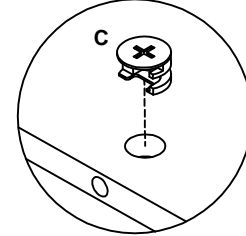
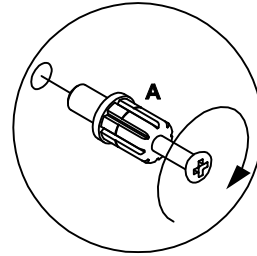
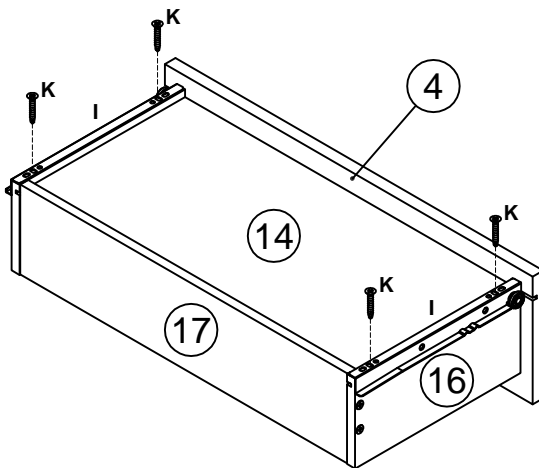
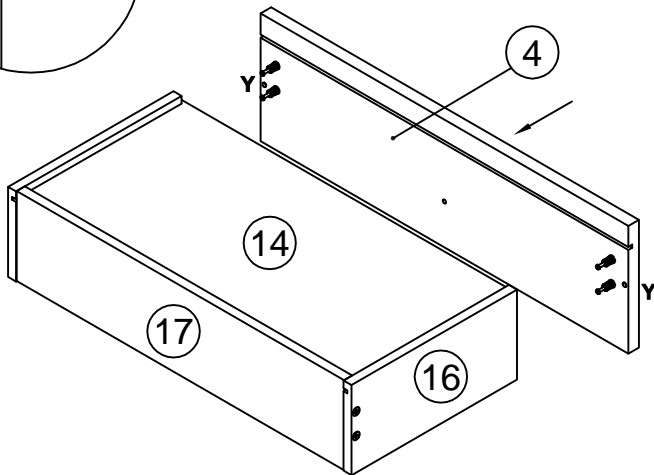
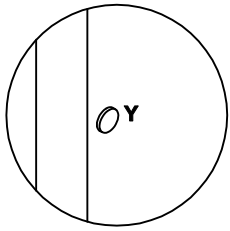
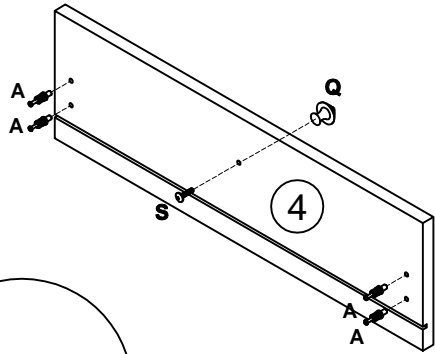
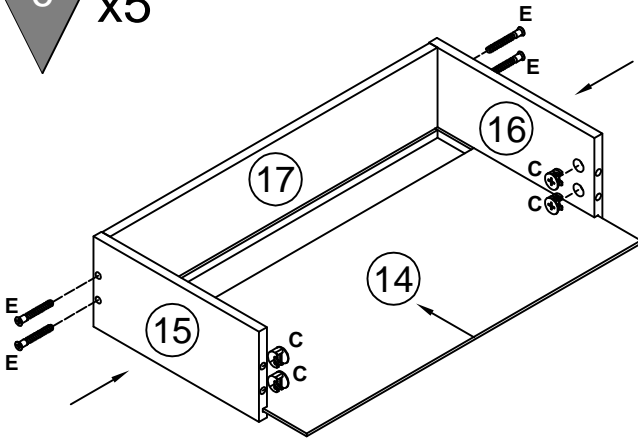

6 x5

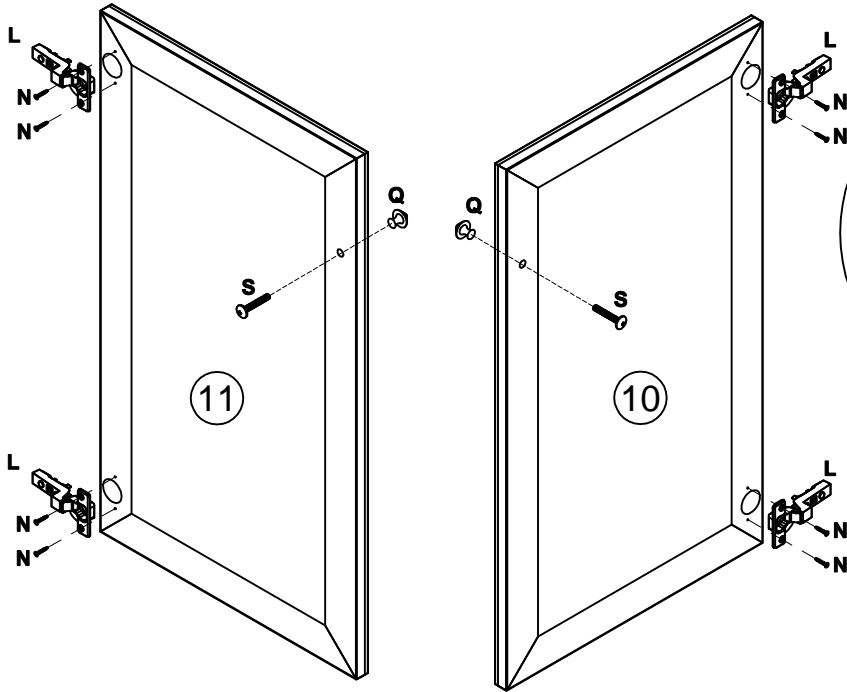

A		7x32
		x40
C		15x10
		x20
E		7x50
		x20
I		L250
		x5
K		3x13
		x20
Q		
		x5
R		M4x22
		x5
Y		
		x10

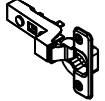
7



- L** 154651  **x4**
- N** 010942  4x16 **x8**
- D** 131263  **x2**
- S** 007088  M4x30 **x2**

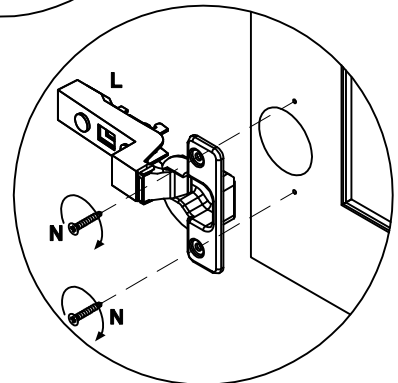
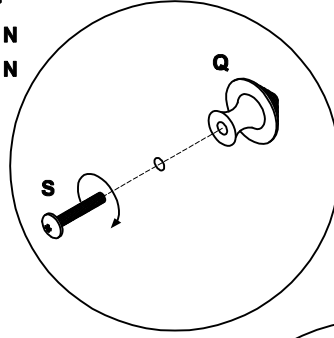

8

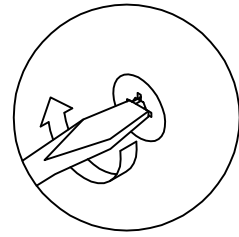
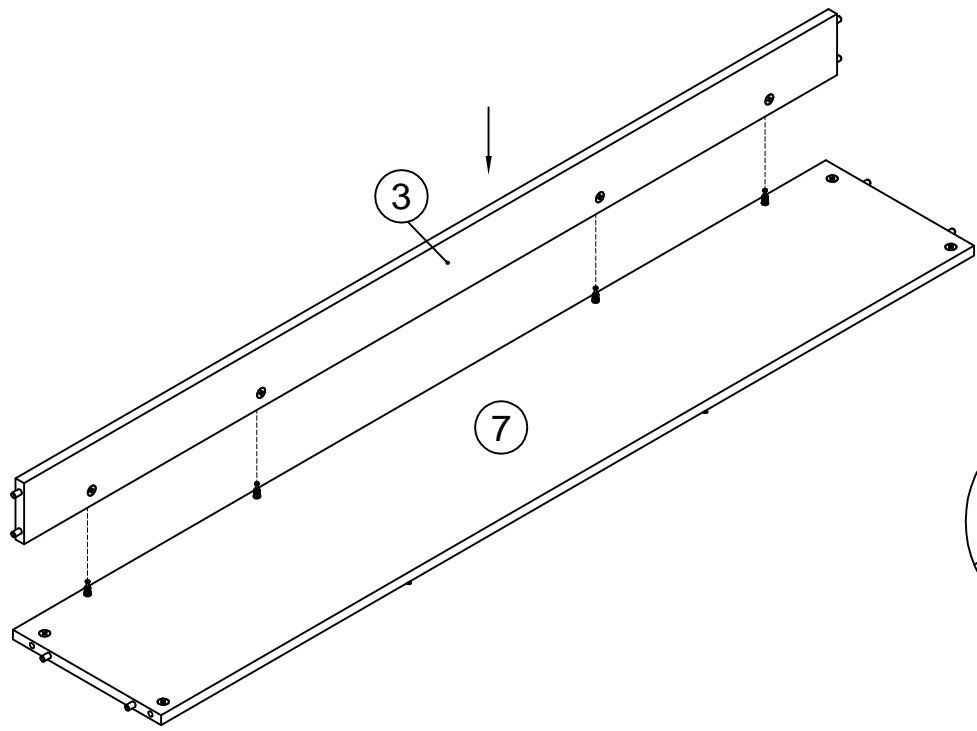

9

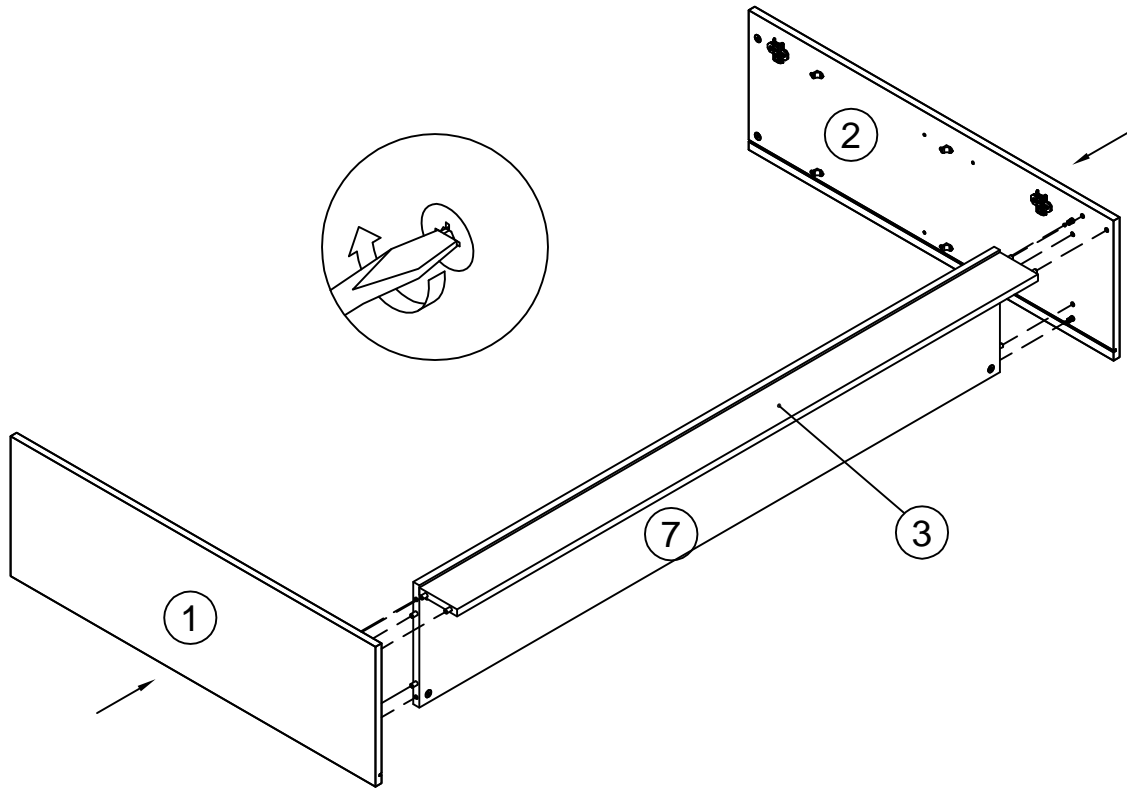

10

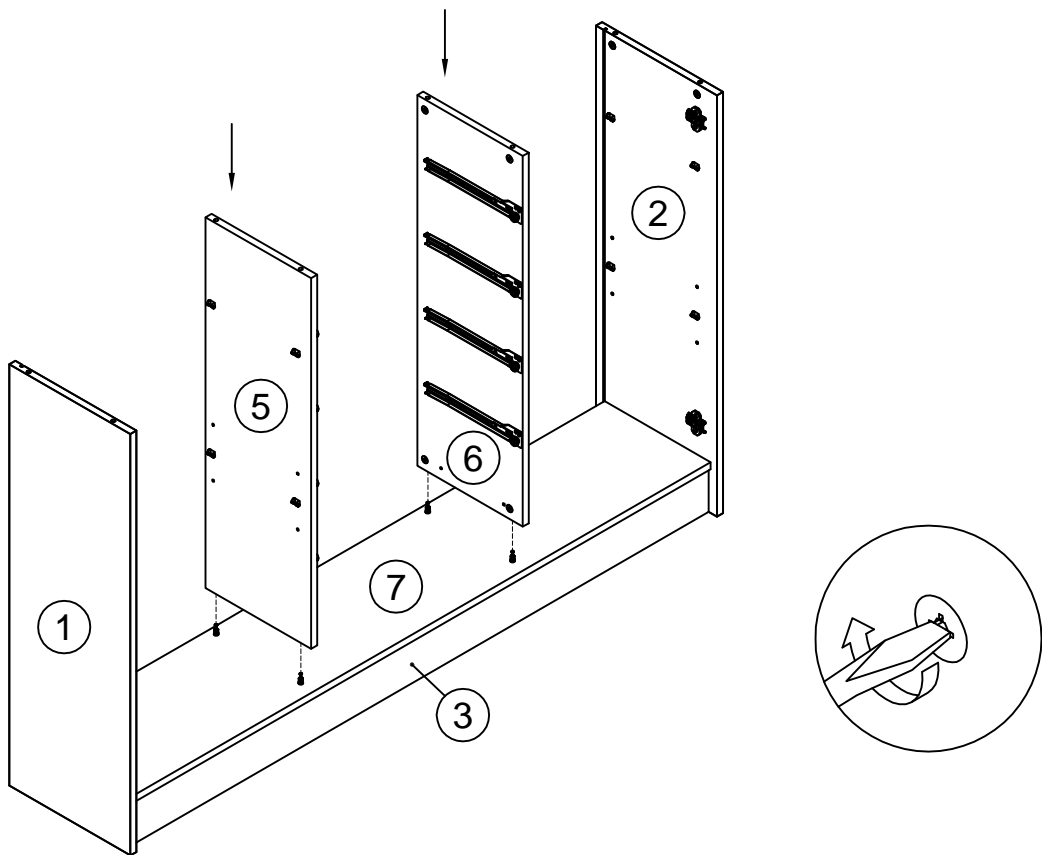



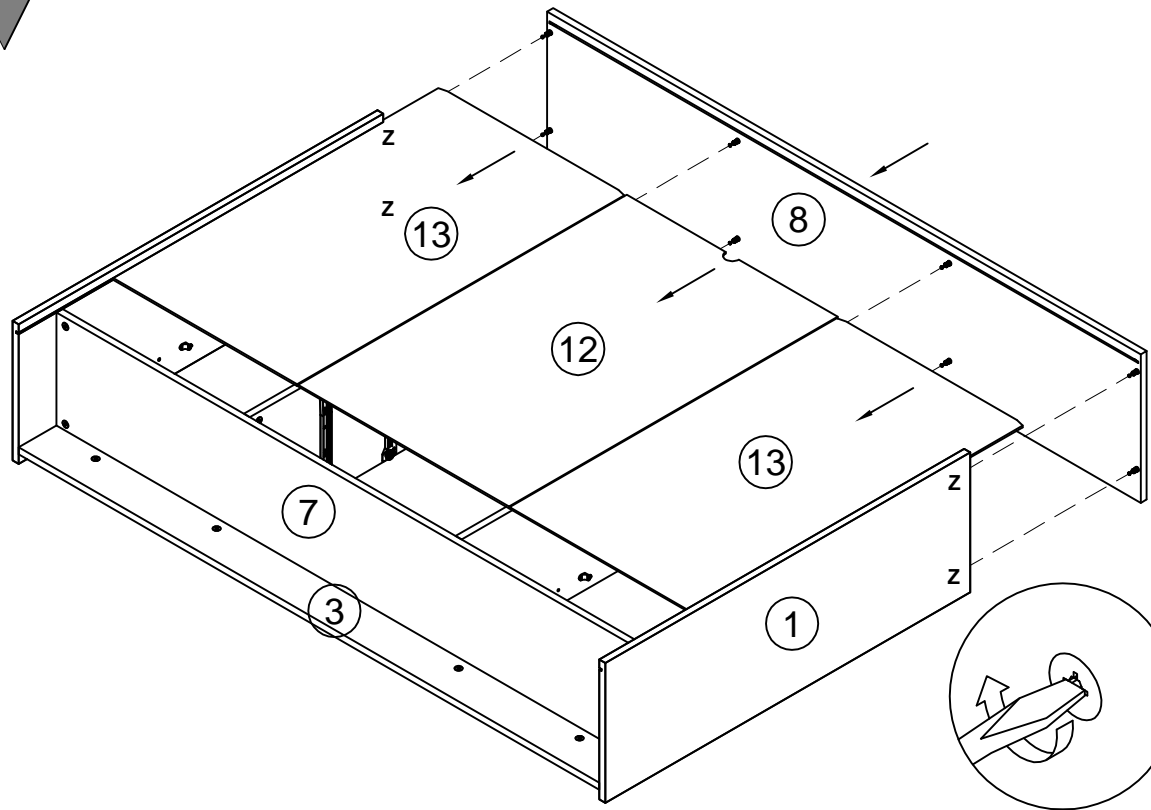

11

Z 20x0.5
100640 x4



12

- F** 135021  x12
- G** 062367  x6
- H** 000759  3x20 x24
- X** 101777  70x50 x2

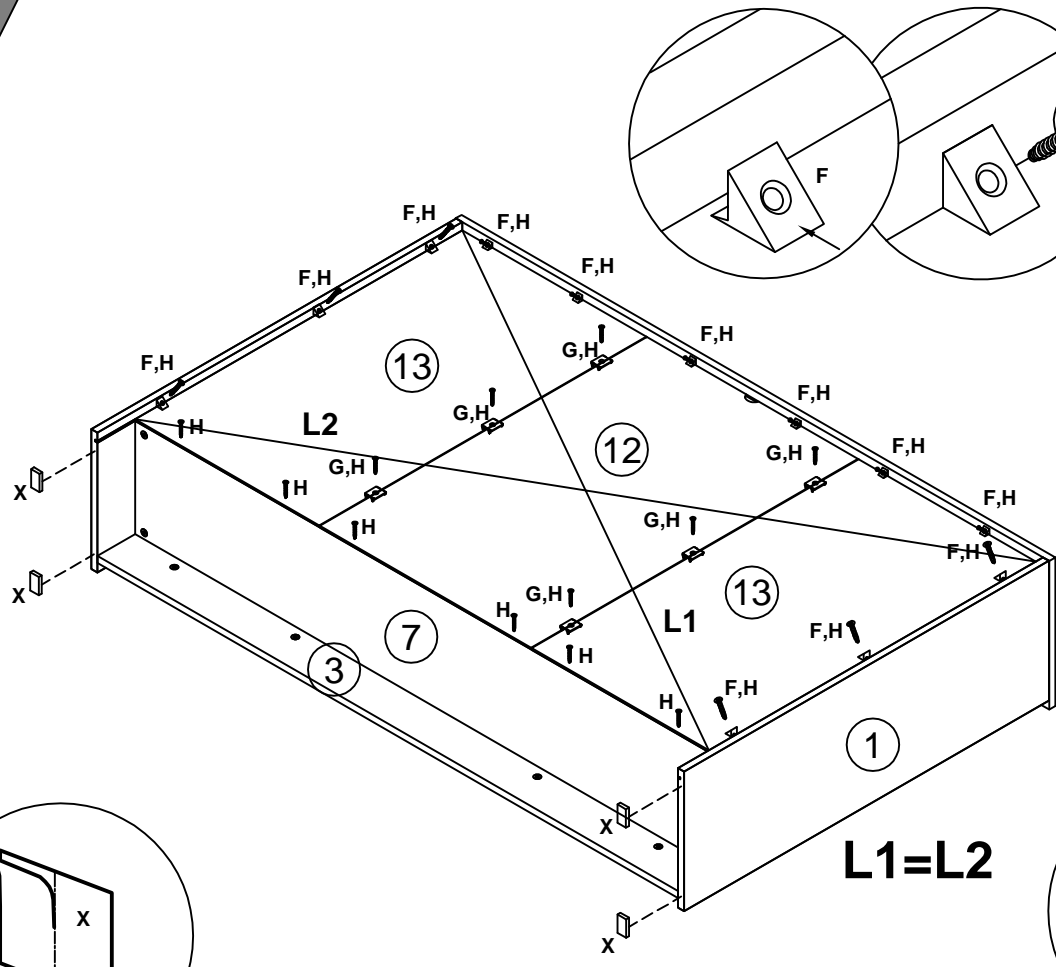

L1=L2

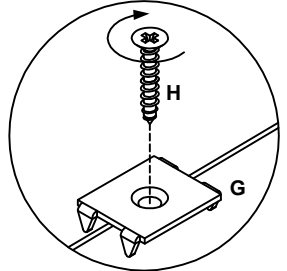
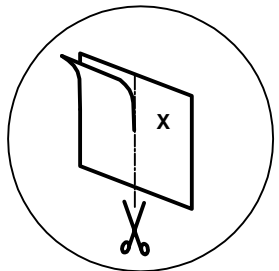

13

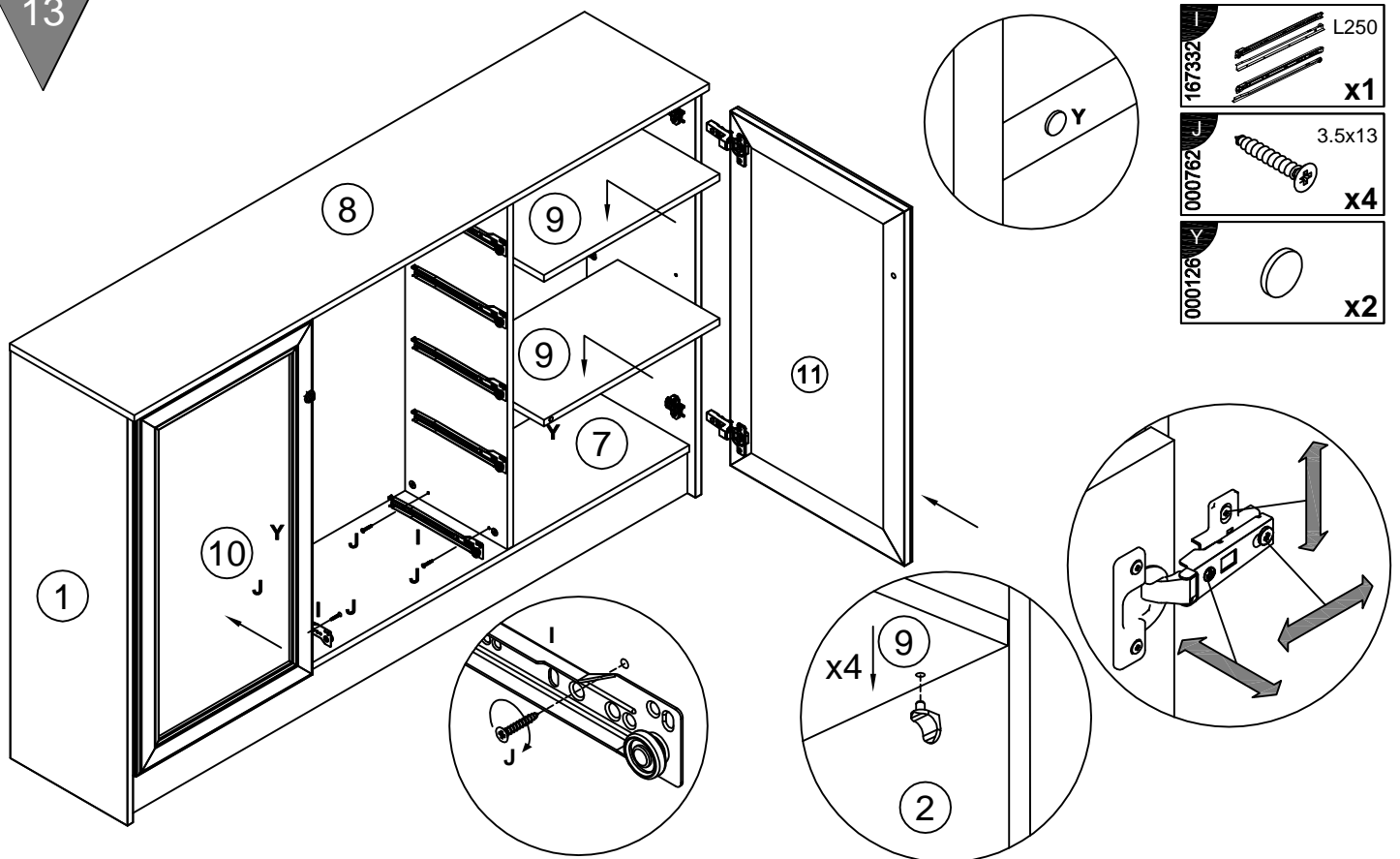

14

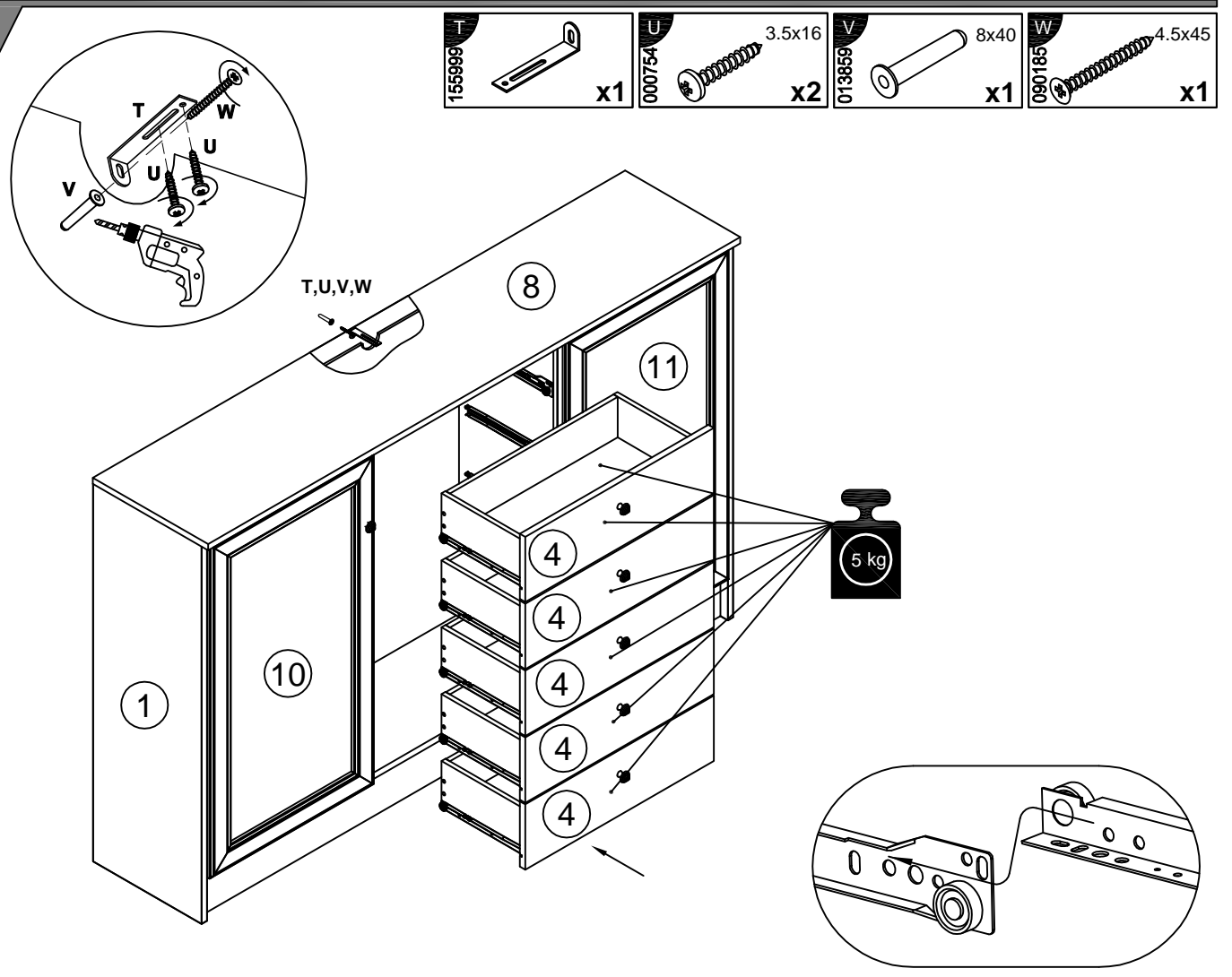

D	Das beidseitig angebrachte Wandbefestigungsmaterial (Dübel und Schrauben) eignet sich nur für festes Mauerwerk (z.B. Beton oder Ziegelwände). Für andere Wandaufbauten sind eventuell Spezialdübel und andere Schrauben notwendig. Ziehen Sie gegebenenfalls eine Fachkraft zurate.
GB	The enclosed wall mounting materials (dowels and screws) are only suitable for solid masonry (e.g. concrete or brick walls). Special dowels and other screws may be necessary for other wall constructions. If necessary, please consult a qualified professional.
FR	Le matériel de fixation murale fourni (chevilles et vis) convient uniquement à des murs solides (p. ex. murs en béton ou en briques). Pour les autres constructions de murs, il faut éventuellement des chevilles spéciales et d'autres vis. Faites-vous conseiller par un spécialiste.
IT	I materiali di fissaggio allegati (tasselli e viti) sono adatti solo ai muri compatti (ad es. di calcestruzzo o mattoni). Per altri tipi di pareti è probabile che occorrono tasselli speciali e altre tipologie di viti. Richiedere eventualmente il consiglio di un esperto.
NL	Het bijgeleverde bevestigingsmateriaal (pluggen en schroeven) is geschikt voor vaste muren (bijv. betonnen of bakstenen muren). Voor andere muurconstructies zijn eventueel speciale pluggen en andere schroeven noodzakelijk. Consulteer eventueel een vakman.
PL	Żalączony zestaw montażowy do zamocowania artykułu do ściany (kołki, wkręty, haki itp.), przeznaczony jest do montażu artykułu na ścianach wykonanych z cegły lub betonu. Przy montażu artykułu na ścianie wykonanej z innych materiałów, należy zastosować odpowiednie do niej zamocowania. W razie wątpliwości prosimy zasięgnąć porady fachowca.
CZ	Přiložený materiál pro montáž na stěnu (hmoždinky a šrouby) je vhodný jen pro pevné zdivo (např. betonové nebo cihlové stěny). Pro jiné skladby stěn budou případně nutné speciální hmoždinky a jiné šrouby. Poradte s odborníkem.
SK	Priložený materiál pre upevnenie na stenu (hmoždinky a skrutky) je vhodný len pre pevné murivo (napr. betónové alebo tehlové steny). Pre iné steny sú potrebné príp. špeciálne hmoždinky a iné skrutky. V prípade potreby sa poradte s odborníkom.
HU	A mellékelt fali rögzítőkészlet (tipli és csavarok) csak tömött falazatban (pl. betonfalban, téglafalban) használható. Más faltípusokhoz speciális tiplire és csavarra lesz szükség. Szükség esetén kérje ki egy szakember véleményét.
RO	Materialul furnizat pentru montajul de perete (dibluri și șuruburi) este adecvat numai pentru zidărie solidă (de exemplu pereți din beton sau din cărămidă). Pentru alte structuri de pereți, este posibil să fie necesare dibluri special, precum și alte șuruburi. Dacă este necesar, consultați un specialist.
TR	Teslimat kapsamındaki duvar tipi sabitleme materyali (dübel ve vidalar) sadece beton ve tuğla duvarlar gibi sağlam duvar yapılar için uygundur. Başka duvar yapılar için özel dübeller veya başka vidalar gerekli. Gerekirse bir uzmandan yardım alın.
RU	Входящий в комплект поставки материал для крепления к стене (дюбели и болты) предназначен только для прочных каменных стен (например, бетонных или кирпичных). Для других типов стен используйте по мере необходимости специальные дюбели и другие болты. По мере необходимости обратитесь за помощью к специалистам.