

living
b.p.c
bonprix collection

Art. Nr. 933136

LKZ 641164

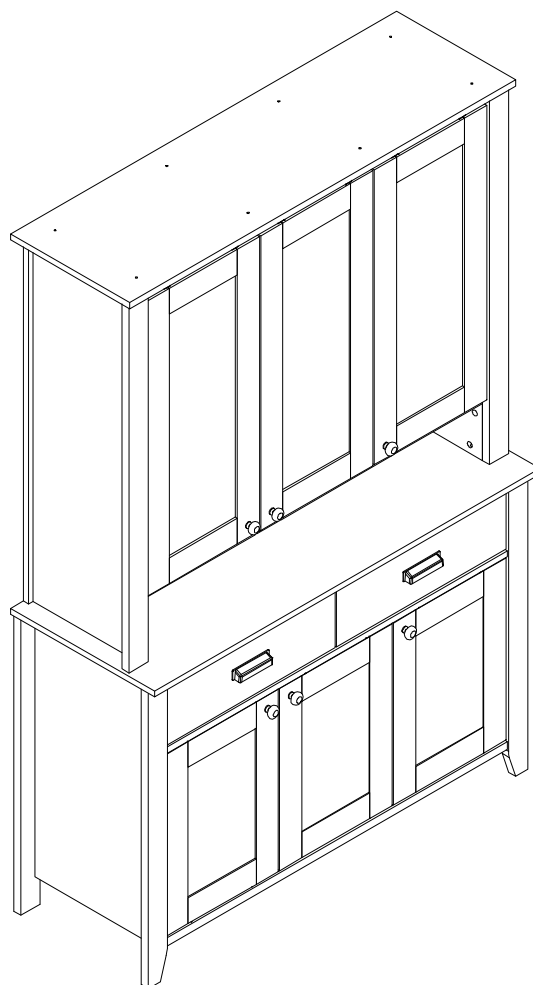

- | | |
|---|-------------------------------------|
| (D) Montageanleitung | (GB) Assembly instructions |
| (FR) Notice de montage | (IT) Istruzioni di montaggio |
| (NL) Handleiding voor de montage | (PL) Instrukcja montazu |
| (CZ) Montážní návod | (SK) Návod na montáž |
| (HU) Szerelési útmutató | (RO) Instruktiuni de montaj |
| (TR) Montaj talimati | (RU) Инструкция по монтажу |

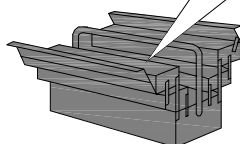
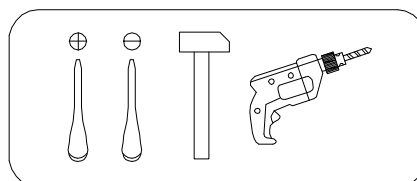
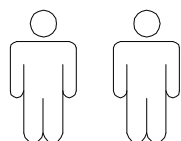

0
10
20
30
40
50
60
70
80
90
100

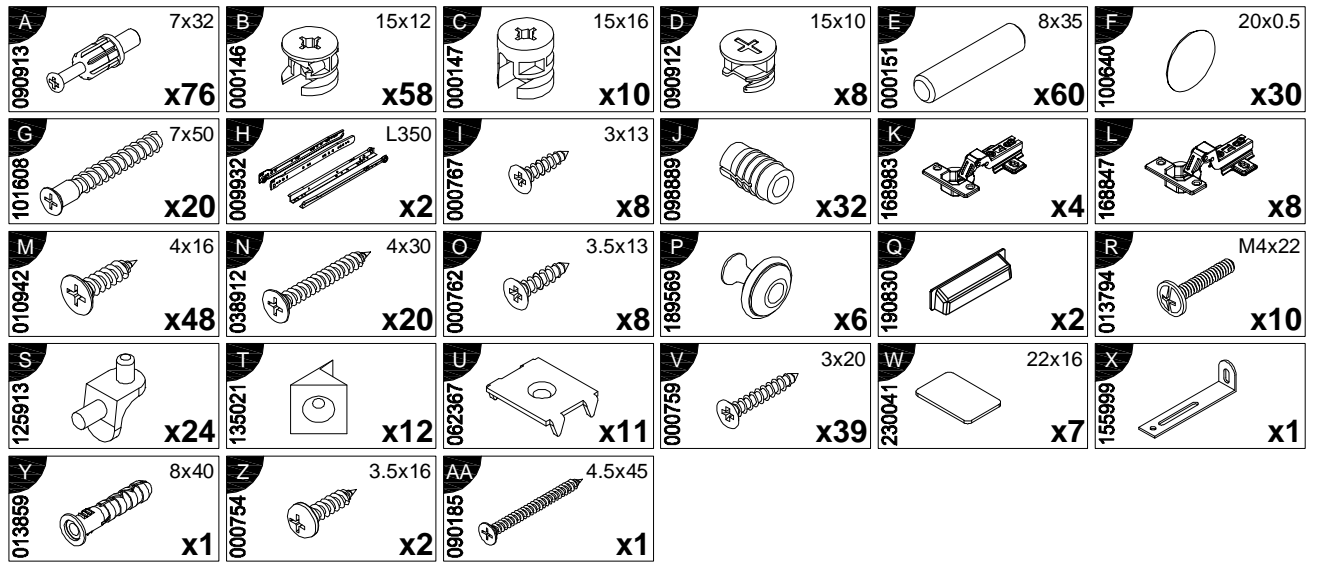

| N | Size/MaB (mm) | Qty | ✓ | N | Size/MaB (mm) | Qty | ✓ |
|----|---------------|-----|---|----|---------------|-----|---|
| 1 | 814x60x22 | 1 | | 21 | 1074x319x22 | 1 | |
| 2 | 814x60x22 | 1 | | 22 | 350x375x16 | 1 | |
| 3 | 814x60x22 | 1 | | 23 | 1074x80x22 | 3 | |
| 4 | 814x60x22 | 1 | | 24 | 1074x395x16 | 1 | |
| 5 | 1004x60x22 | 2 | | 25 | 1074x377x16 | 1 | |
| 6 | 1004x30x16 | 2 | | 26 | 496x354x16 | 3 | |
| 7 | 350x118x12 | 2 | | 27 | 803x354x16 | 3 | |
| 8 | 350x118x12 | 2 | | 28 | 1214x452x16 | 1 | |
| 9 | 480x118x12 | 2 | | 29 | 1214x375x16 | 1 | |
| 10 | 732x378x16 | 1 | | 30 | 350x317x16 | 2 | |
| 11 | 732x378x16 | 1 | | 31 | 708x317x16 | 2 | |
| 12 | 1004x324x16 | 1 | | 32 | 708x375x16 | 1 | |
| 13 | 1004x324x16 | 1 | | 33 | 1074x511x3 | 1 | |
| 14 | 533x160x16 | 1 | | 34 | 1073x198x3 | 1 | |
| 15 | 533x160x16 | 1 | | 35 | 1084x296x3 | 2 | |
| 16 | 155x1074x16 | 1 | | 36 | 1084x255x3 | 1 | |
| 17 | 488x376x16 | 1 | | 37 | 490x347x3 | 2 | |
| 18 | 168x376x16 | 1 | | 38 | 200x104x16 | 1 | |
| 19 | 811x318x16 | 1 | | 39 | 200x104x16 | 1 | |
| 20 | 1074x319x16 | 1 | | | | | |

Service - Dienstverlening - Serwis - Servis - Сервисная служба

Name - Naam - Nazwa - Isim - Название

Nr. - No. - Номер

Тур - Type - Tip - Тип

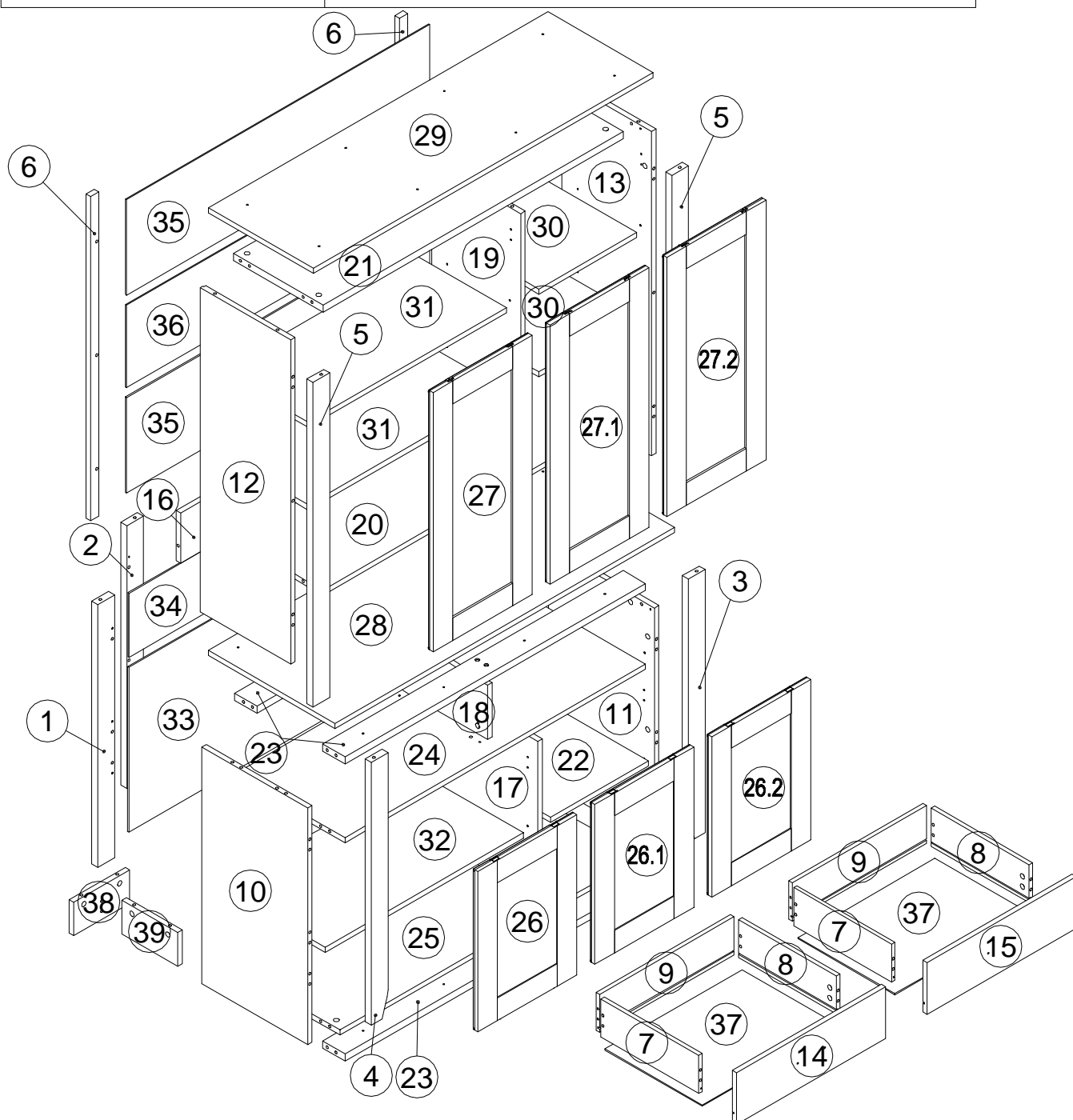
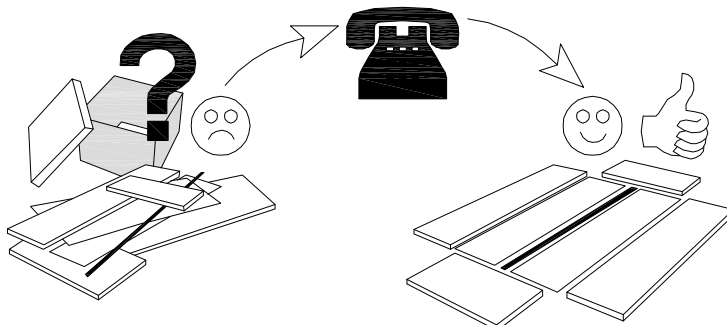
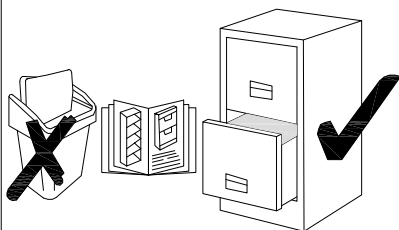

1

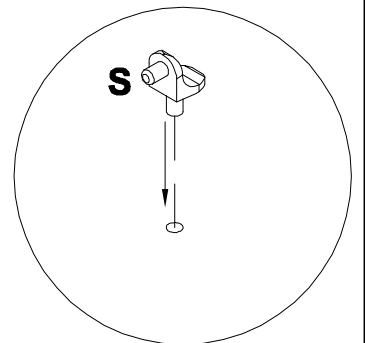
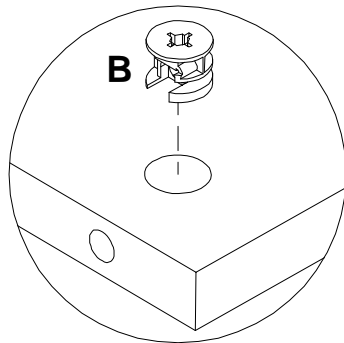
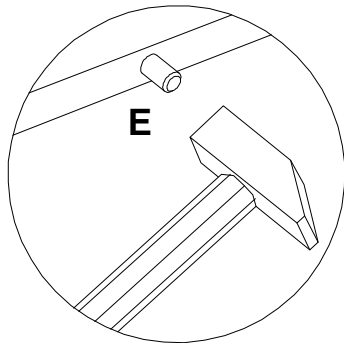
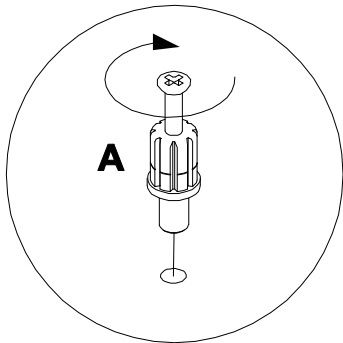
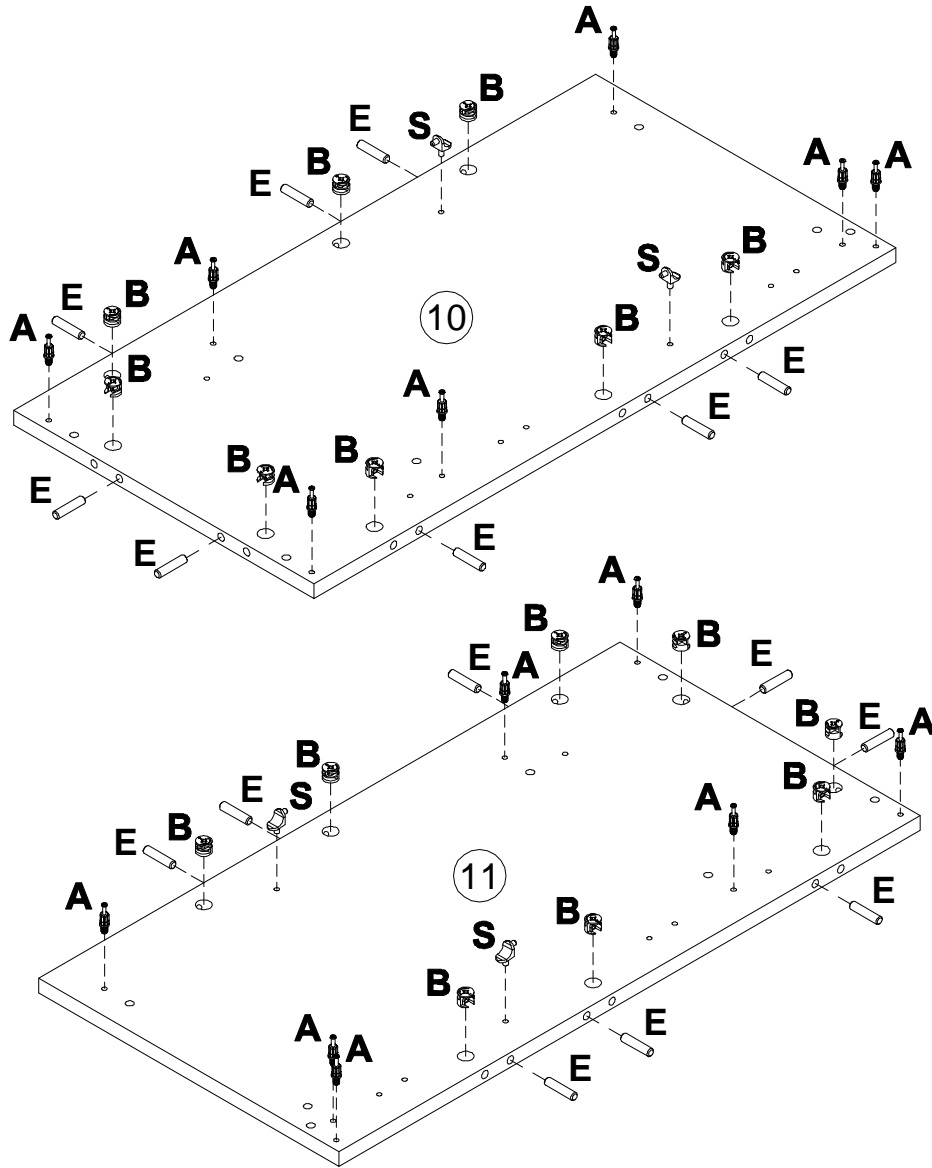
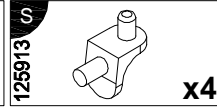
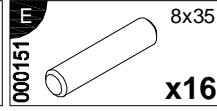
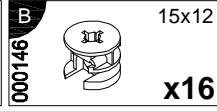
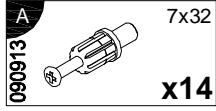

2

H 009932 L350
x2

J 098889
x12

L 168847
x4

M 010942 4x16
x8

O 000762 3.5x13
x4

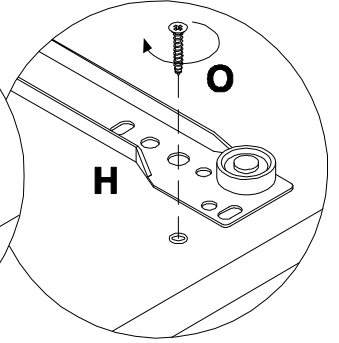
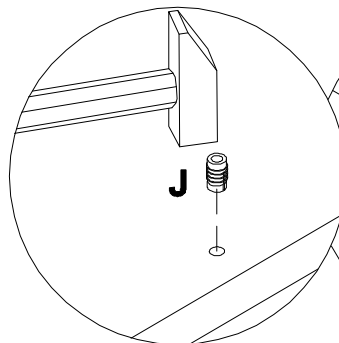
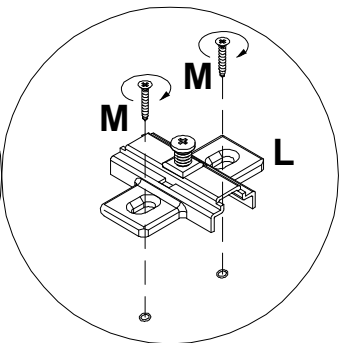
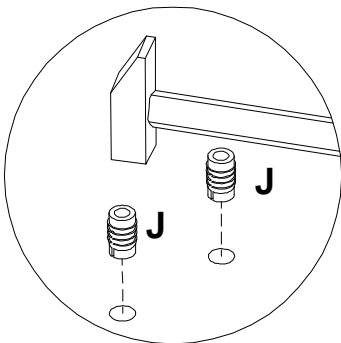
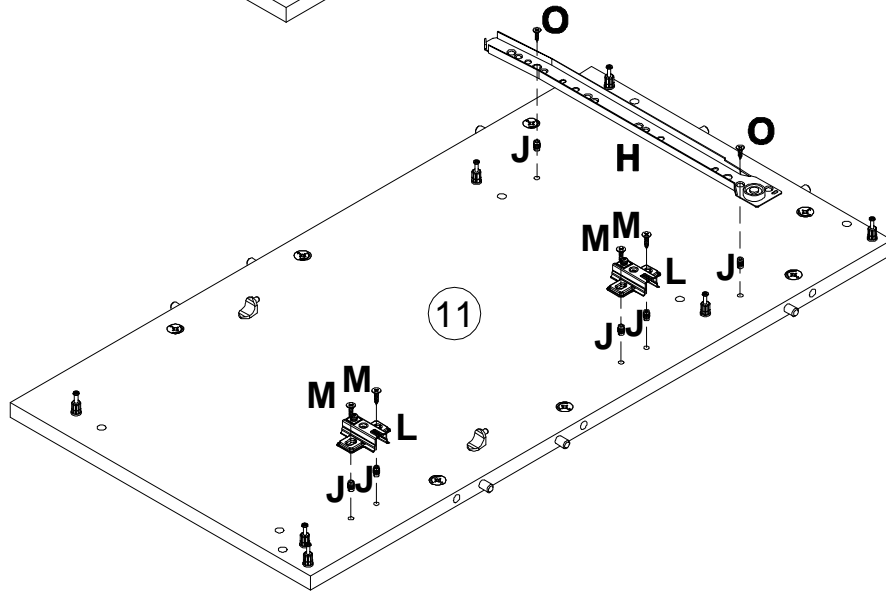
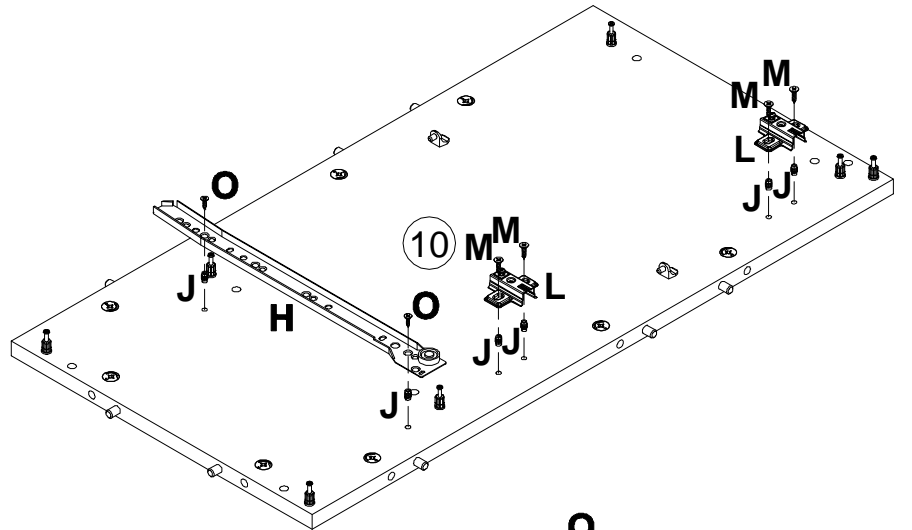

3

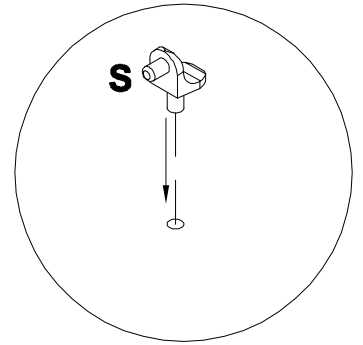
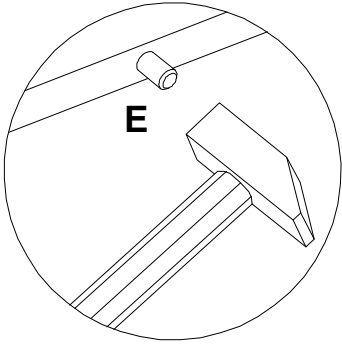
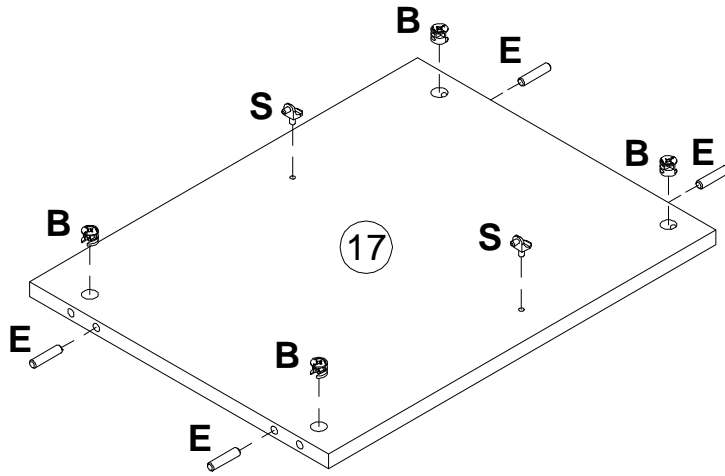
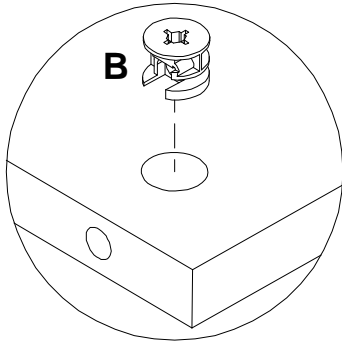
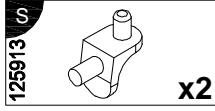
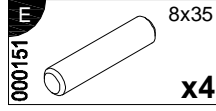
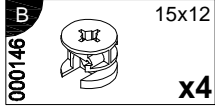

4

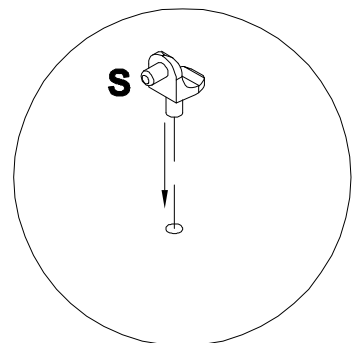
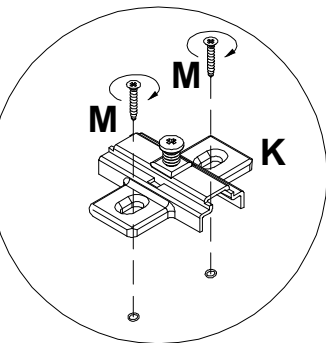
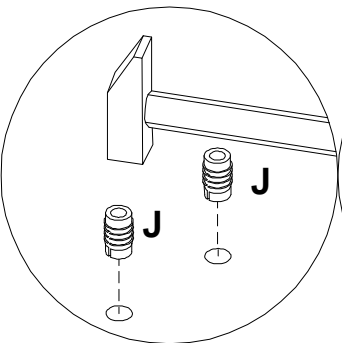
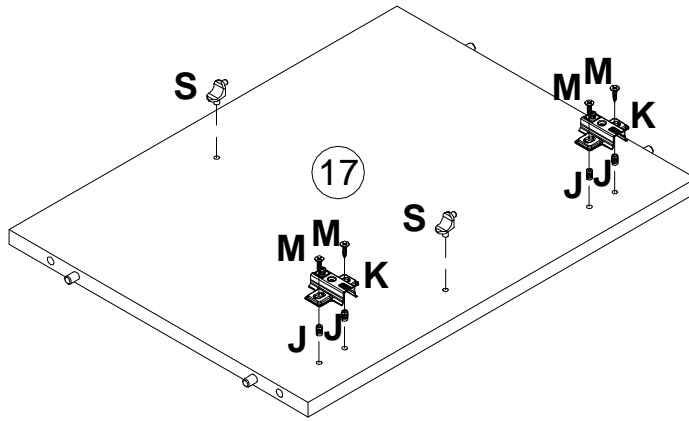
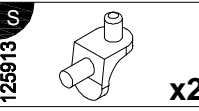
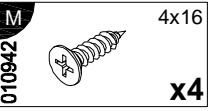
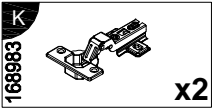
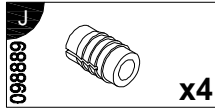

5

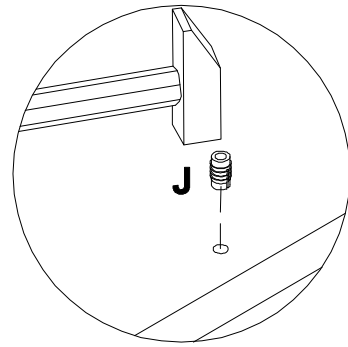
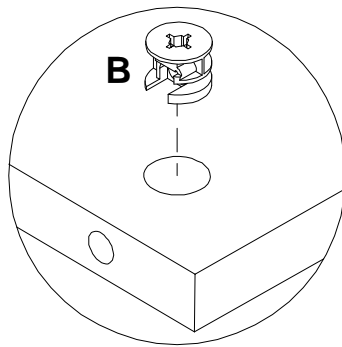
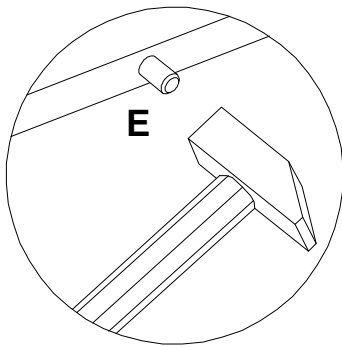
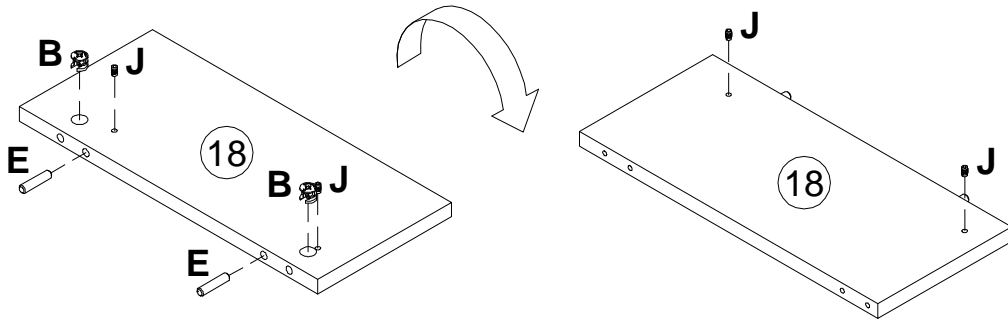
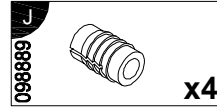
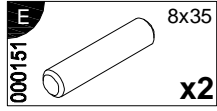
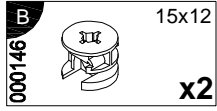

6

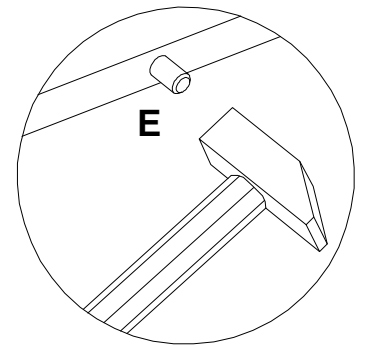
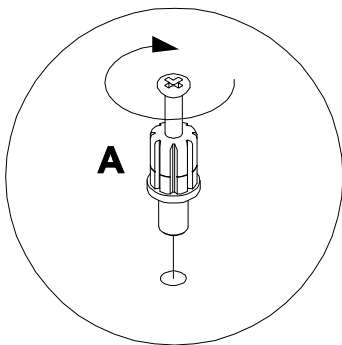
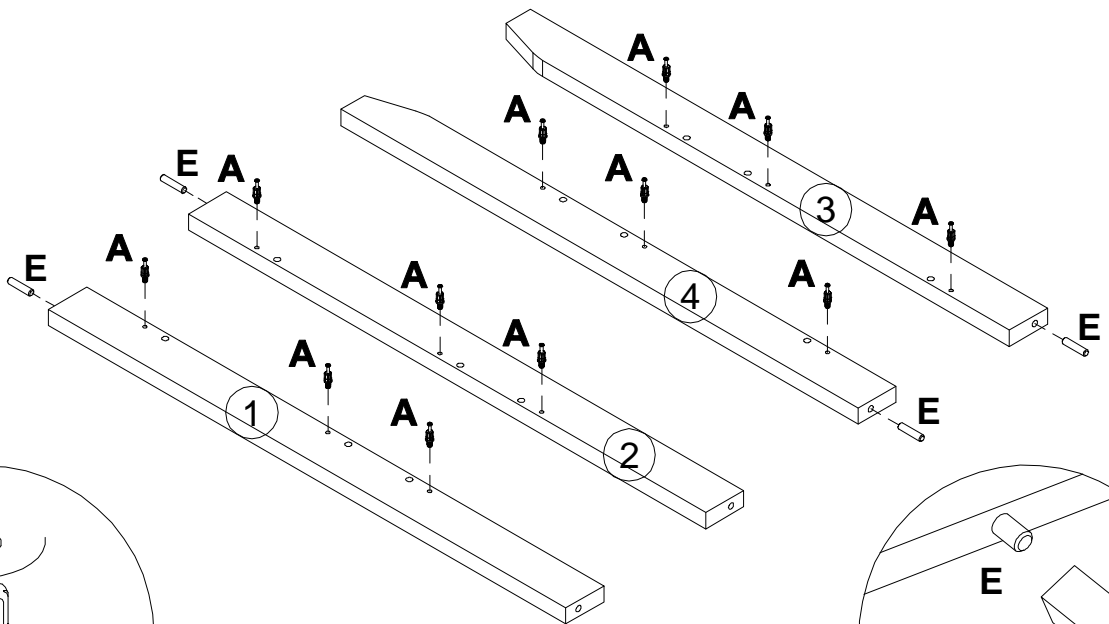
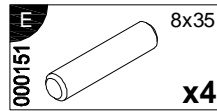
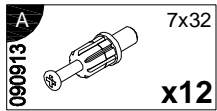

7 x3

000147



15x16

x6

000151

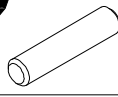

8x35

x6

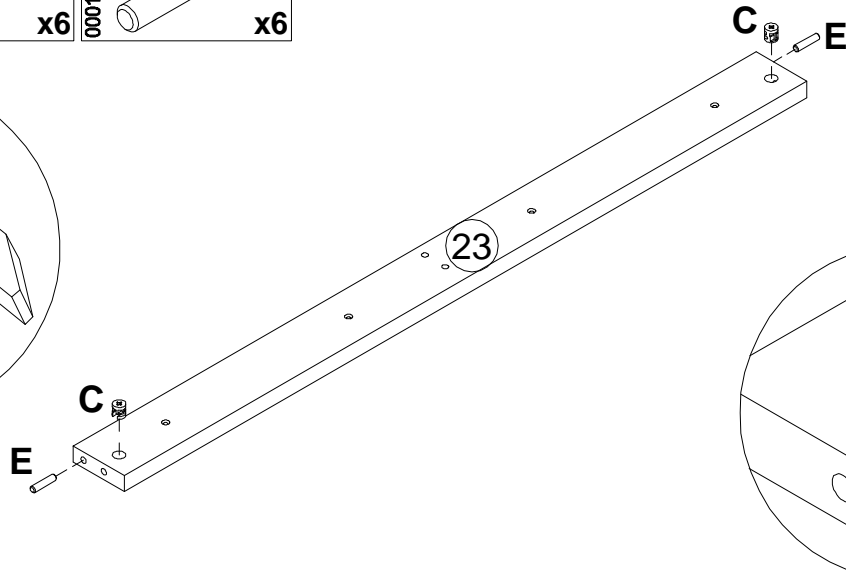
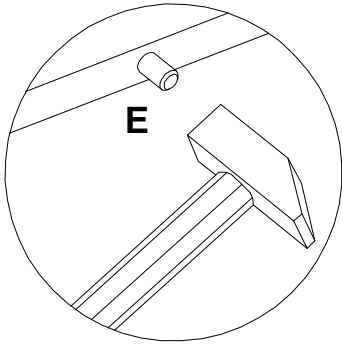

8

090913

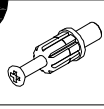

7x32

x6

000146

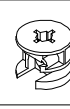

15x12

x4

000151

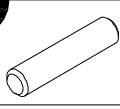

8x35

x4

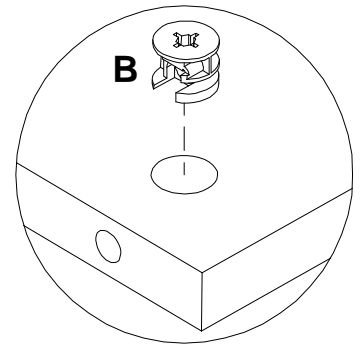
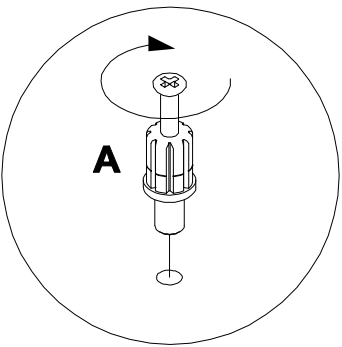
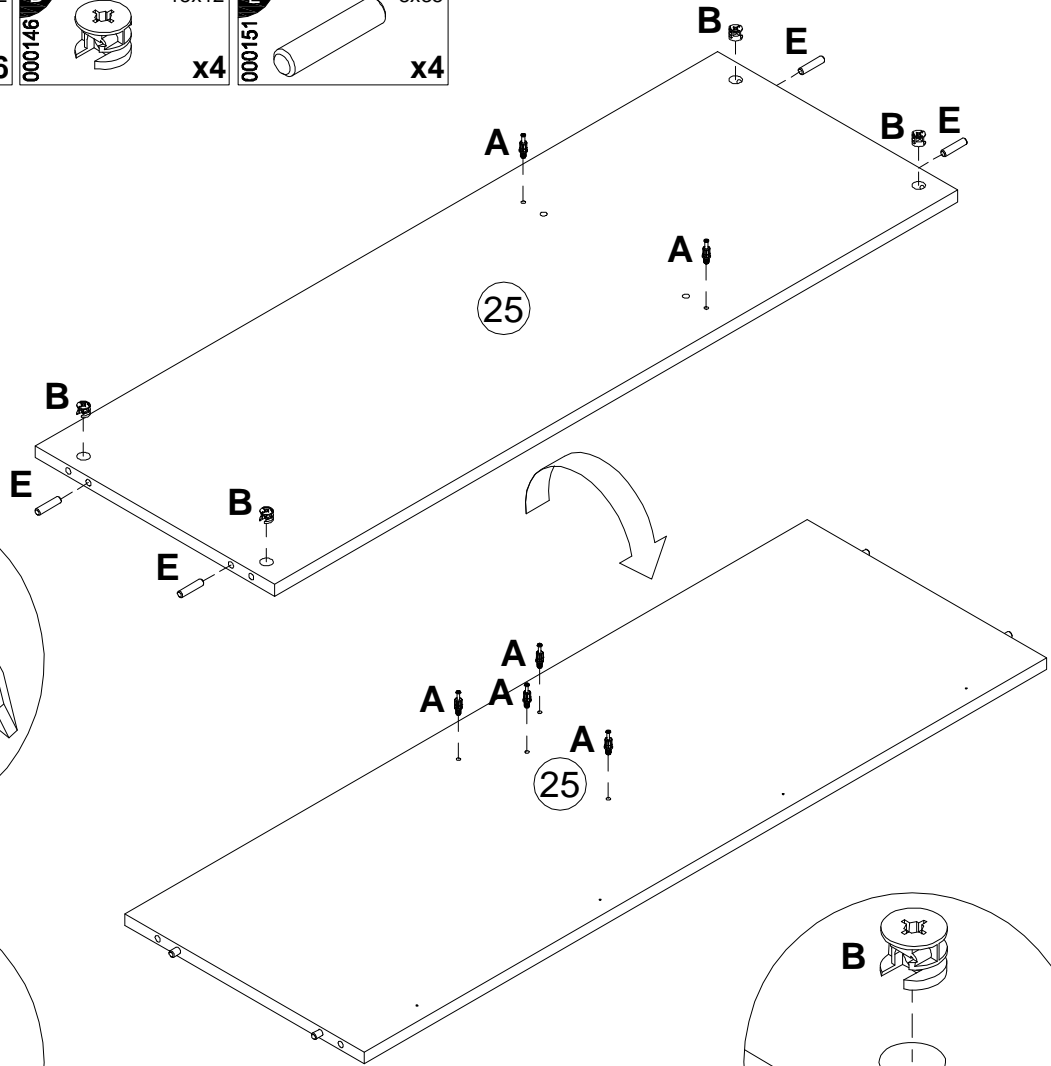
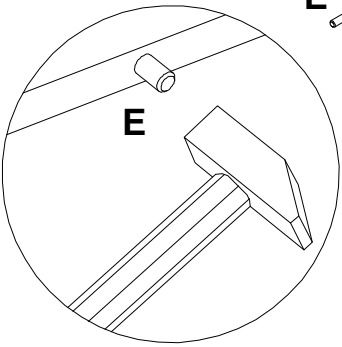

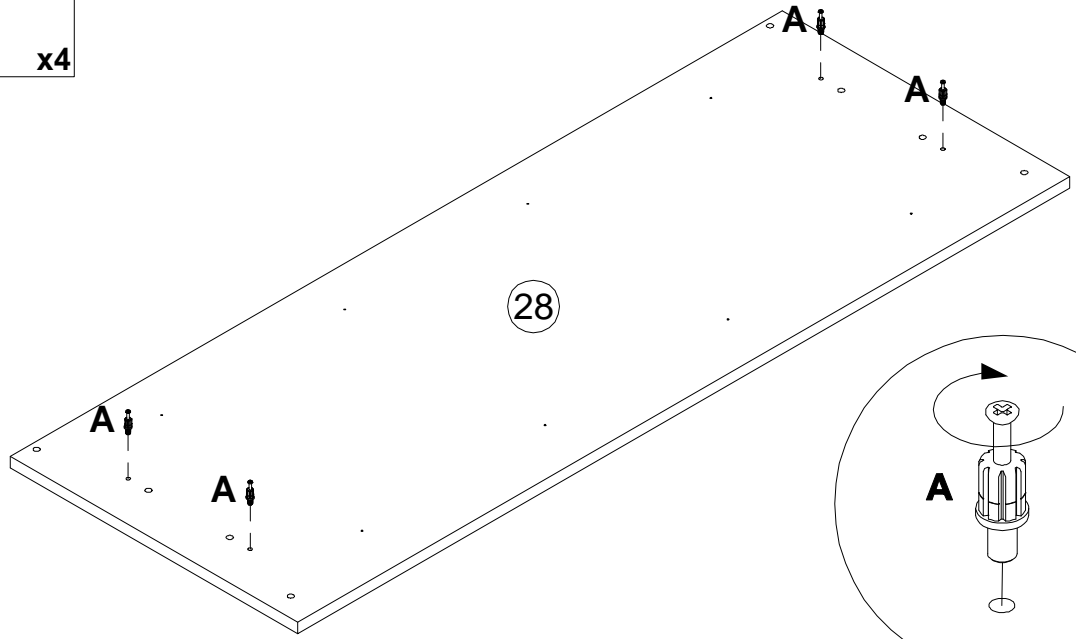

9

| | | |
|----------|---|-----------|
| A |  | 7x32 |
| 090913 | | x4 |



28

10

| | | | | | | | | |
|----------|---|-----------|----------|---|-----------|----------|---|-----------|
| A |  | 7x32 | B |  | 15x12 | E |  | 8x35 |
| 090913 | | x4 | 000146 | | x4 | 000151 | | x4 |

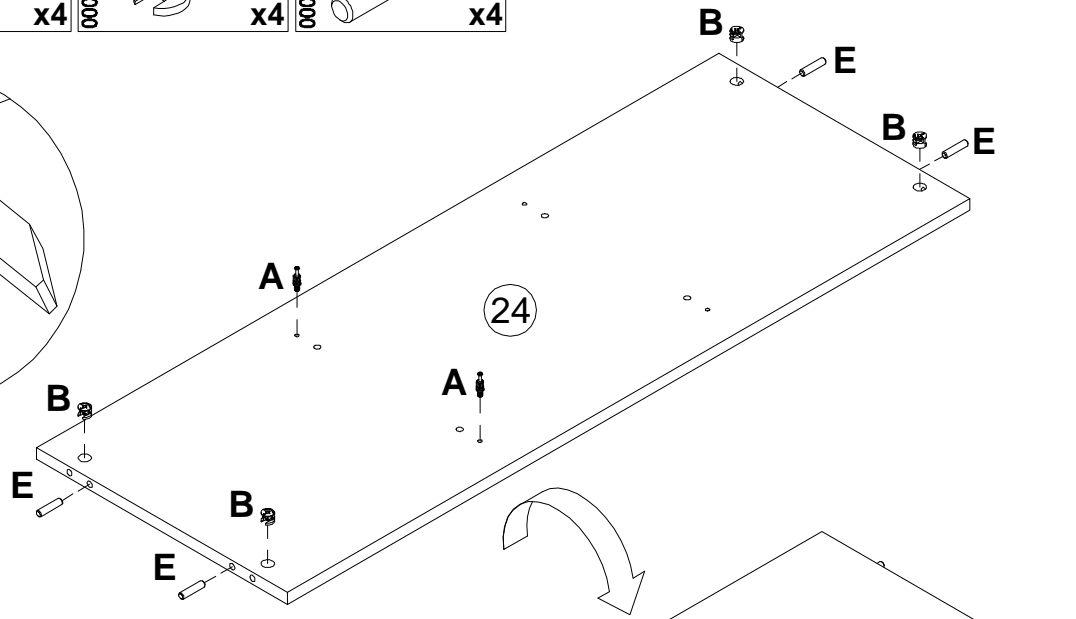
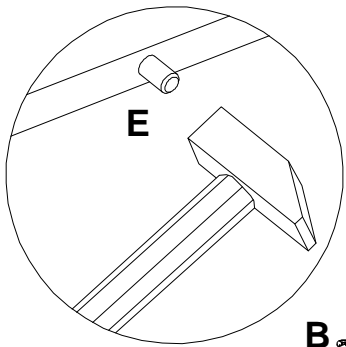

24

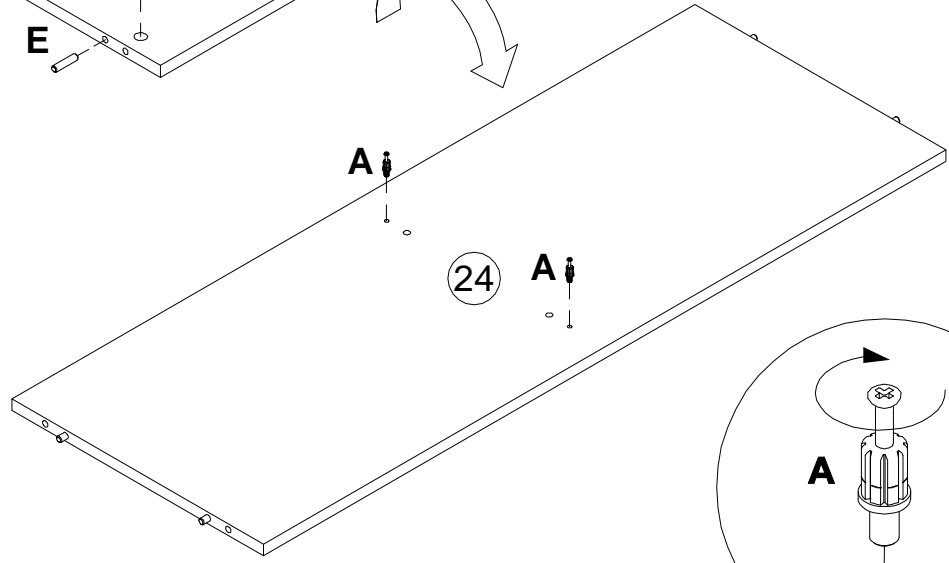
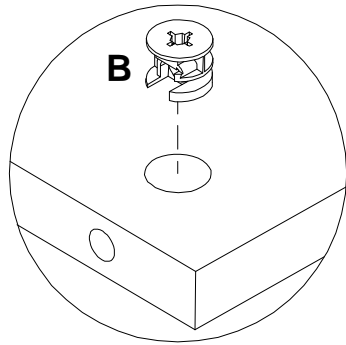

24

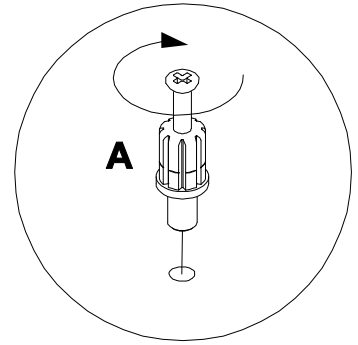

11

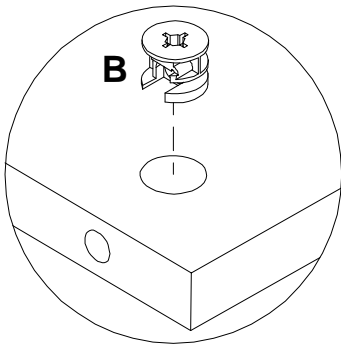
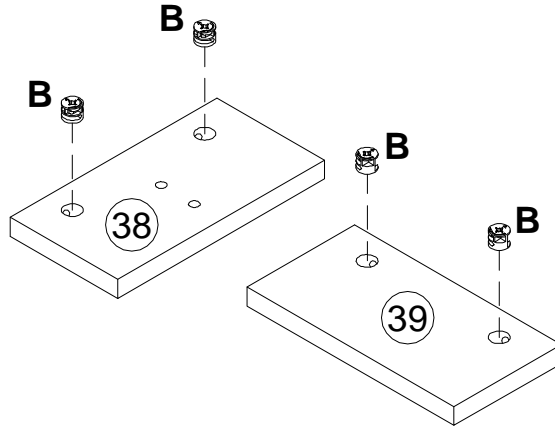
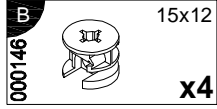

12

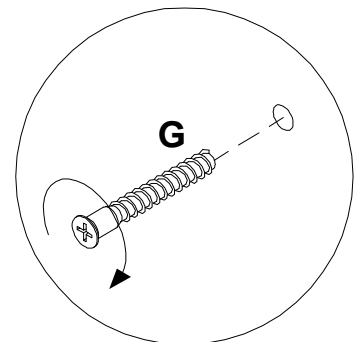
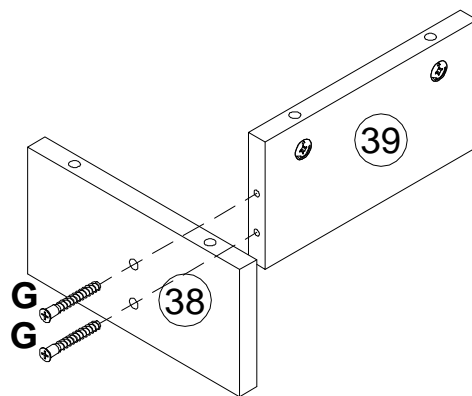
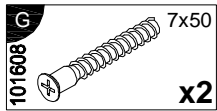

13

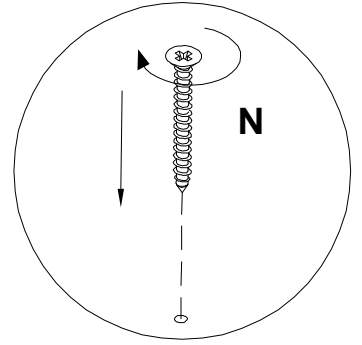
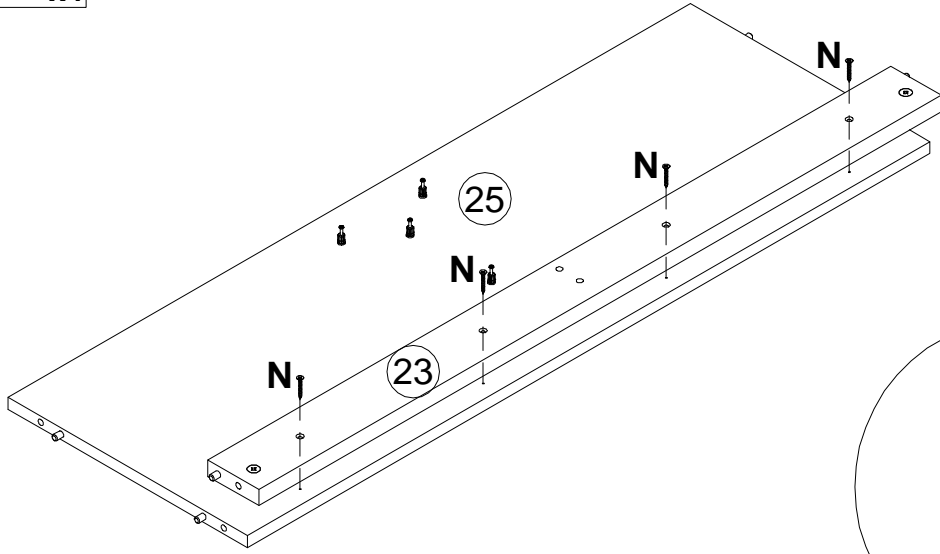
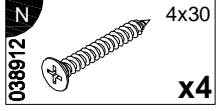

14

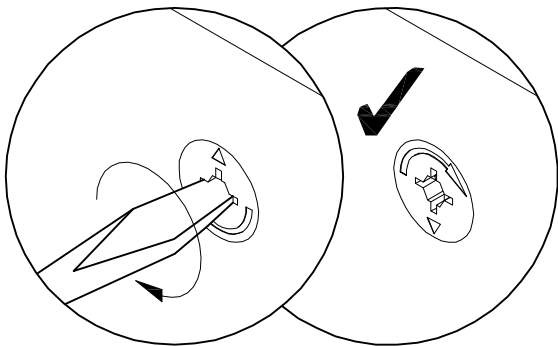
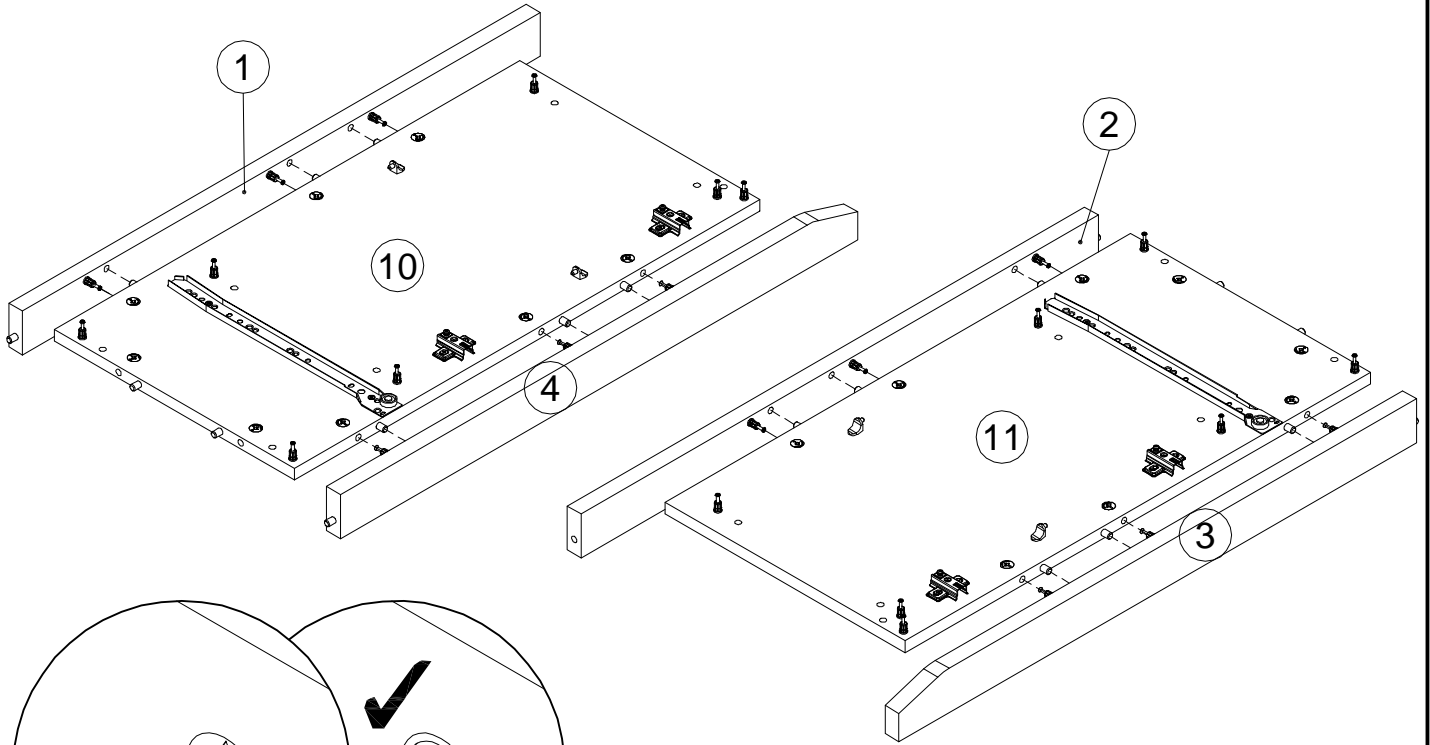

15

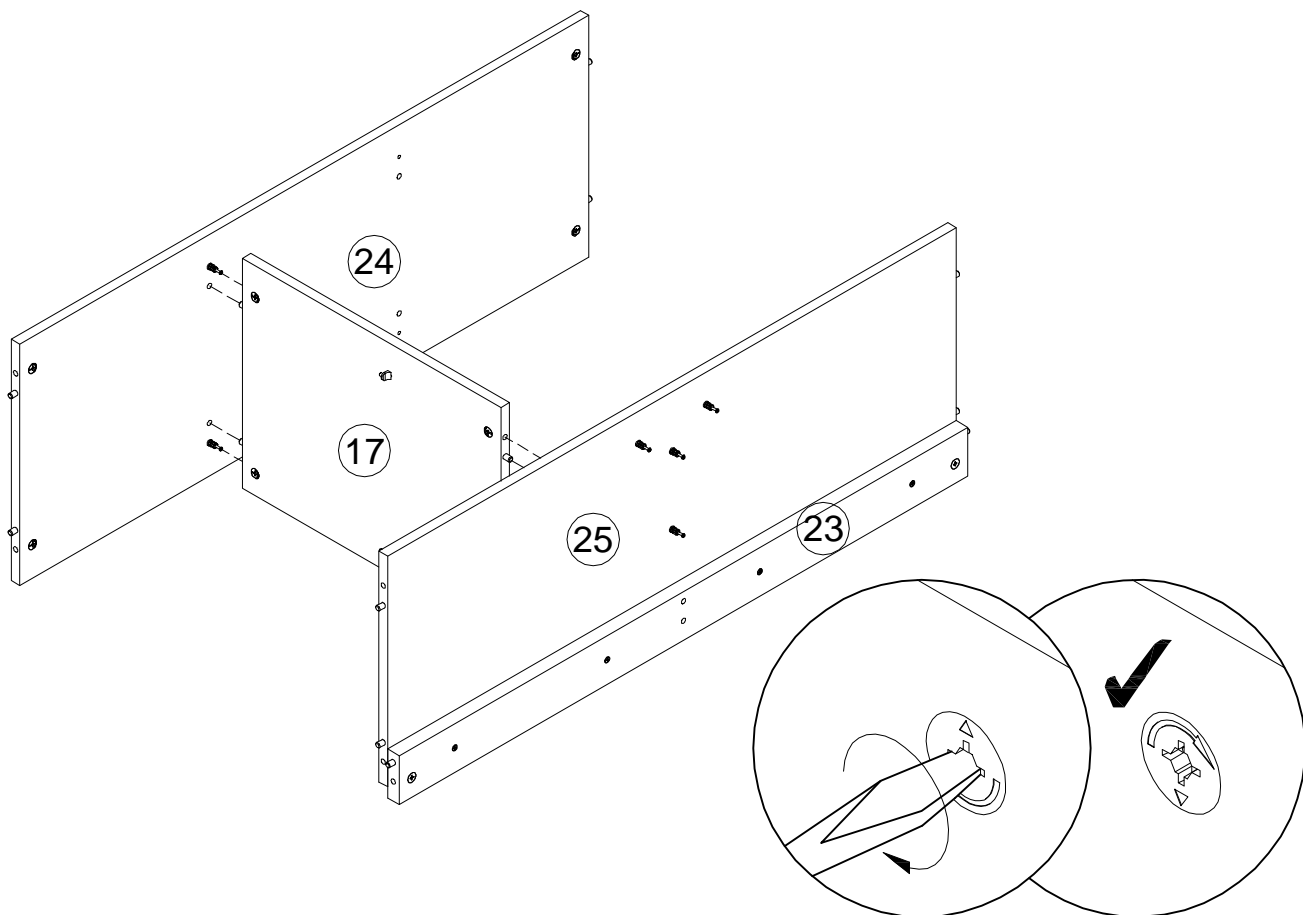

16

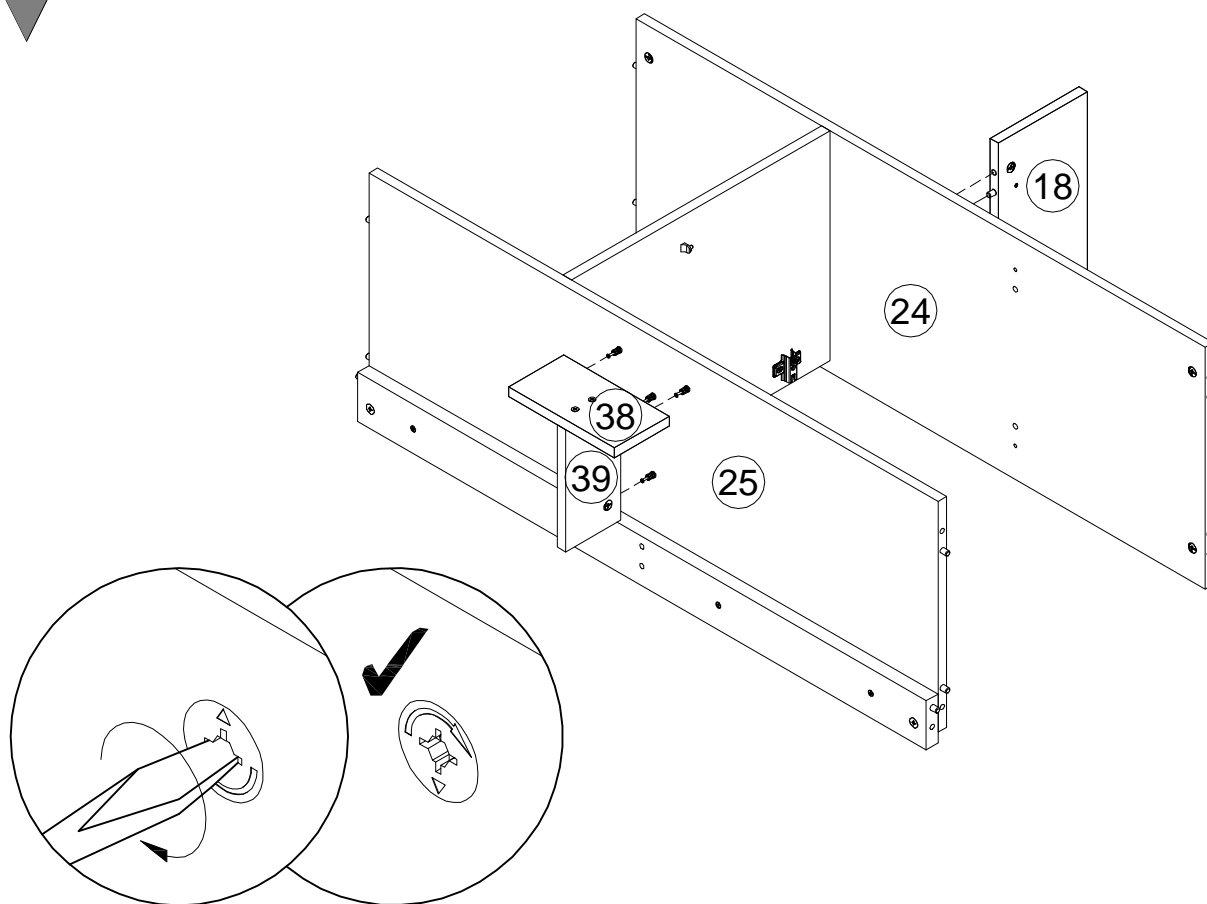

17

G
101608 7x50
x4

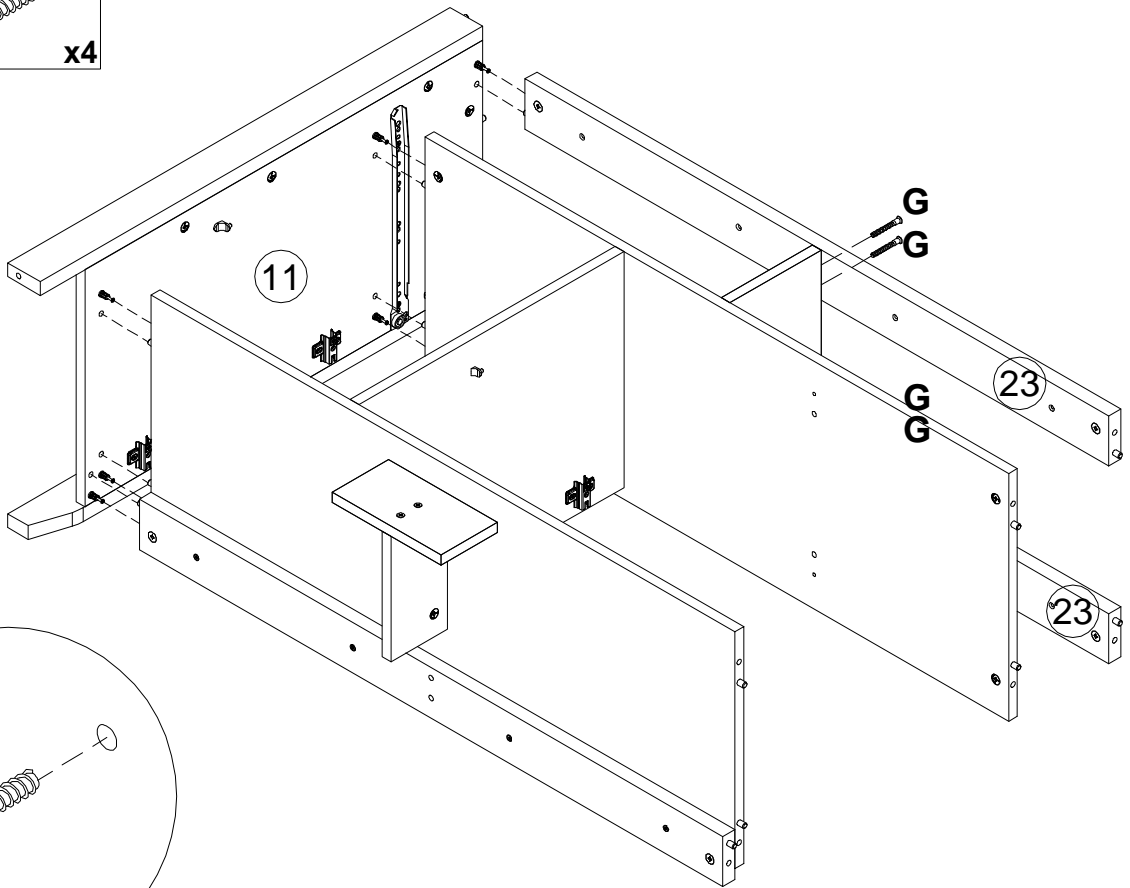

18

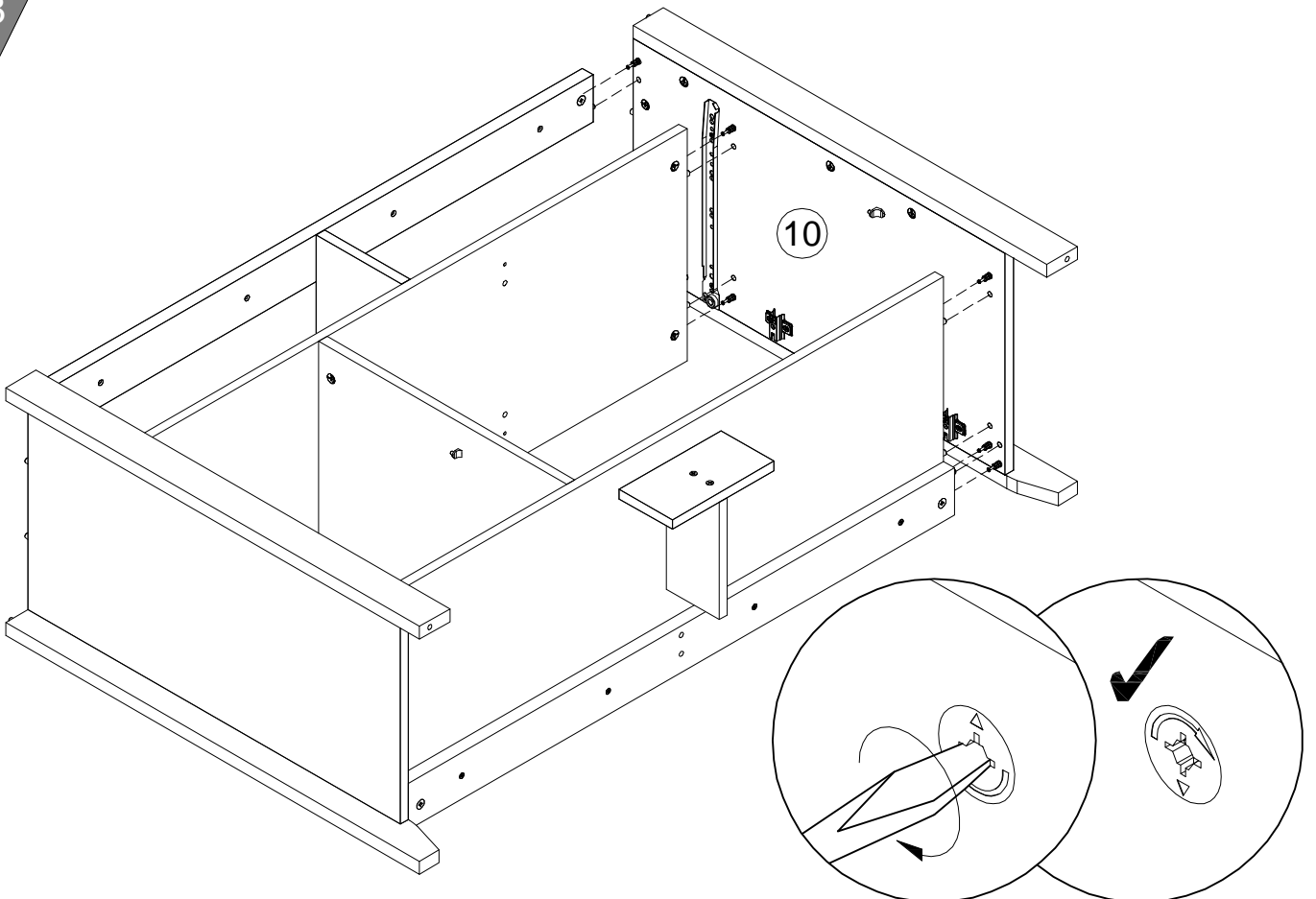

19

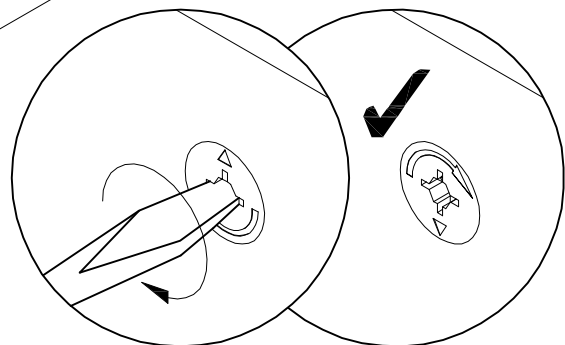
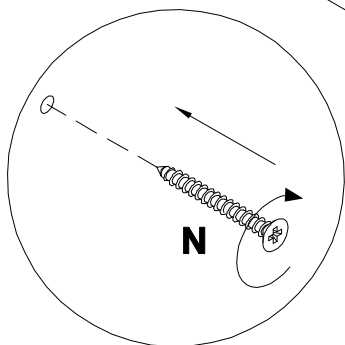
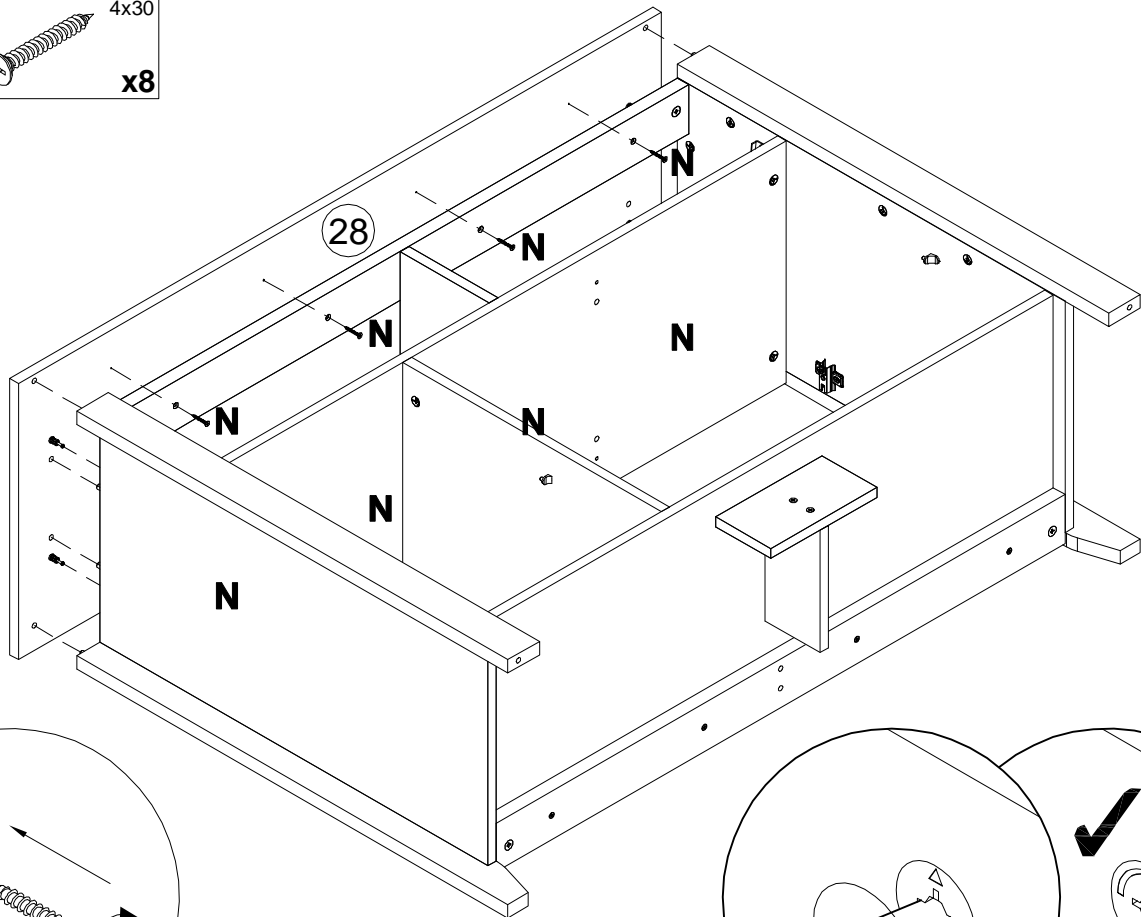
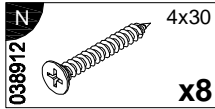

20

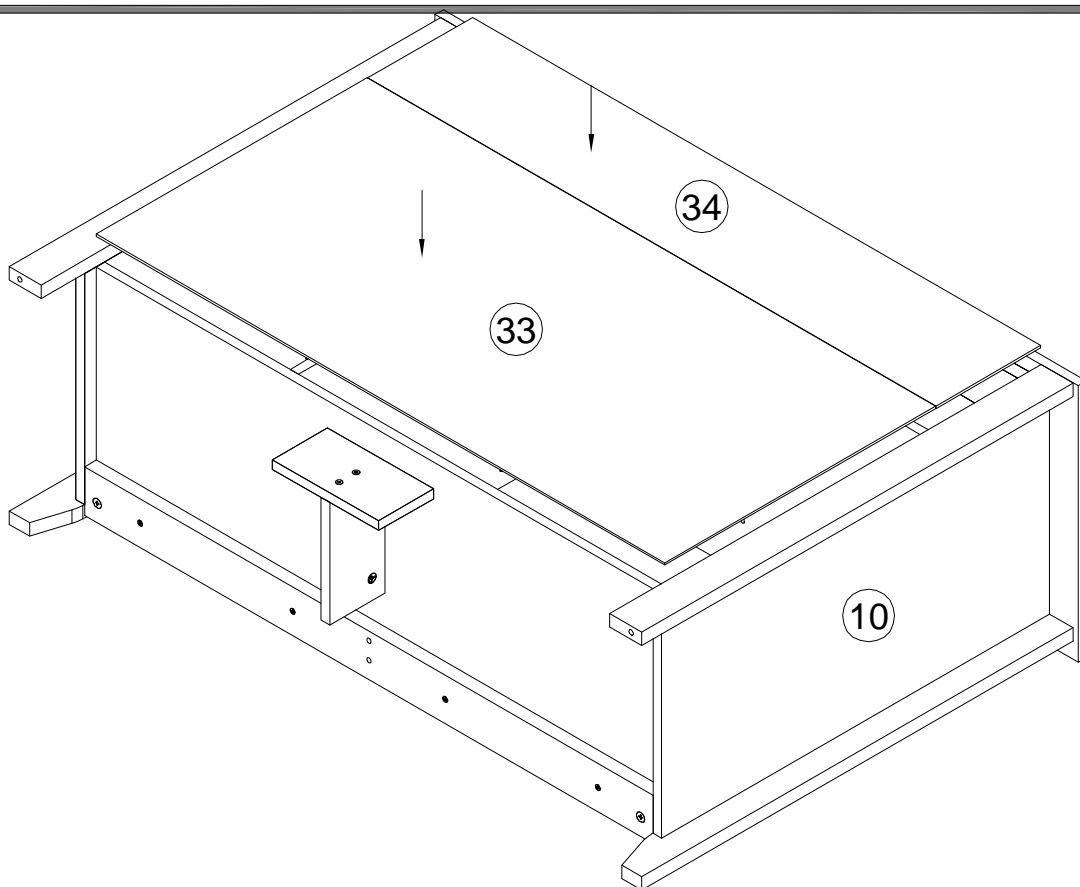

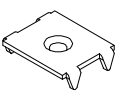
| | | | |
|----------------------------|---|--------------------------------------|--------------------------------------|
| <p>U 062367 x5</p> |  | <p>V 000769 3x20 x15</p> | <p>W 230041 22x16 x7</p> |
|----------------------------|---|--------------------------------------|--------------------------------------|

L1=L2

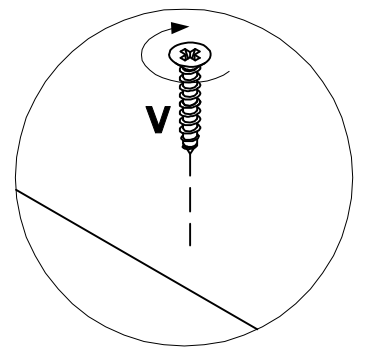
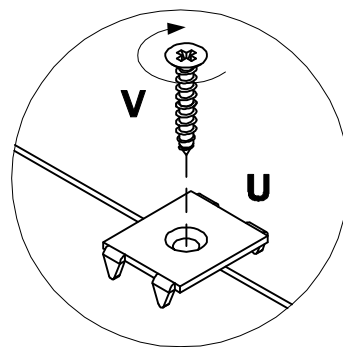
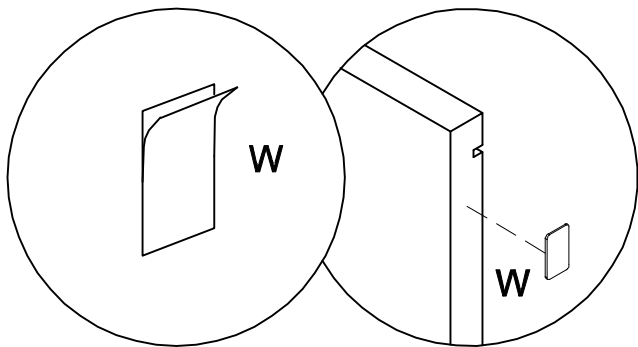
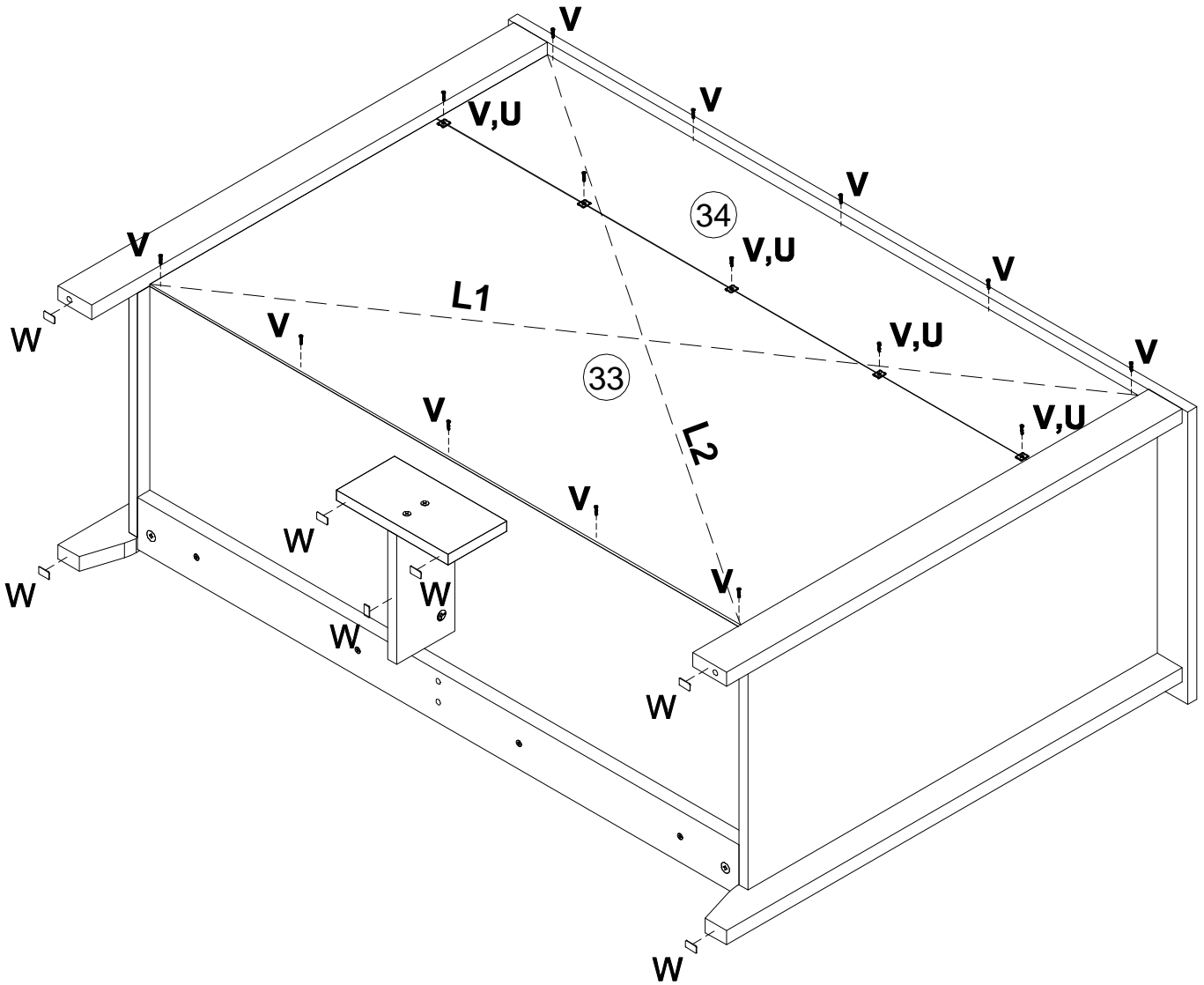

22

009932

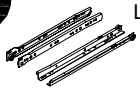

L350

x2

000762



3.5x13

x4

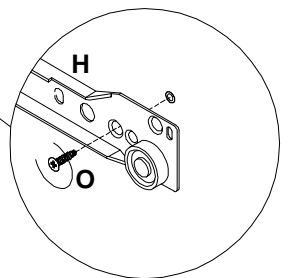
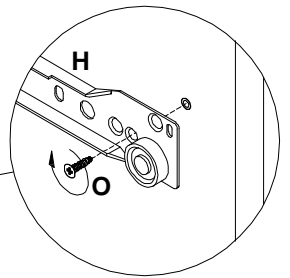
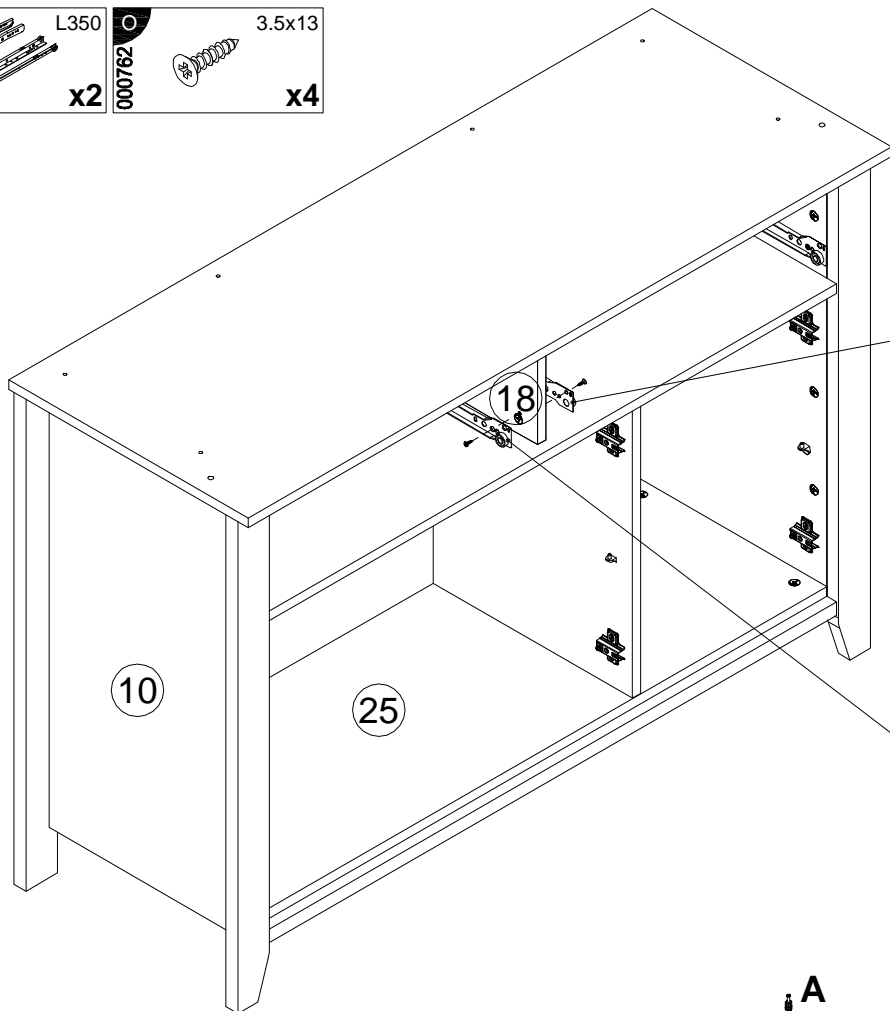

23

090913

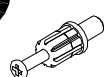

7x32

x6

100640



20x0.5

x16

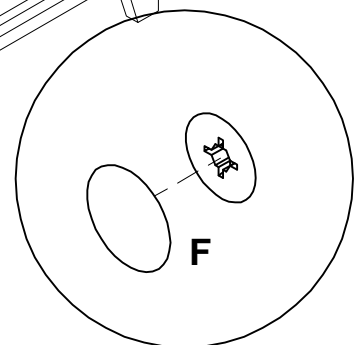
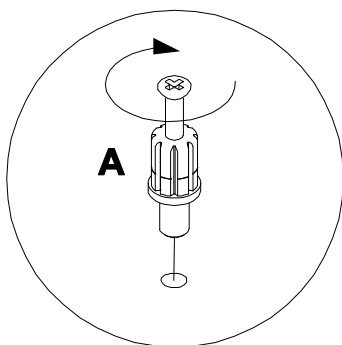
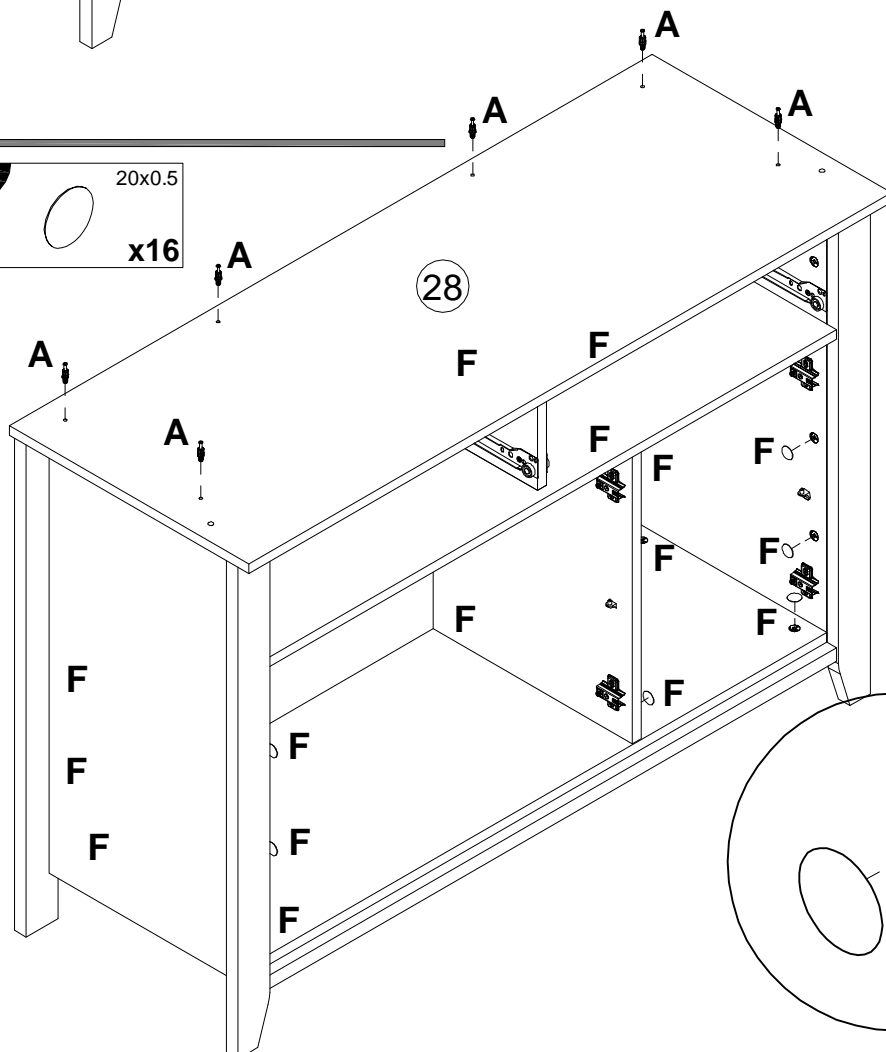

24

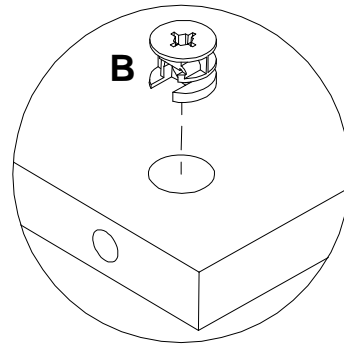
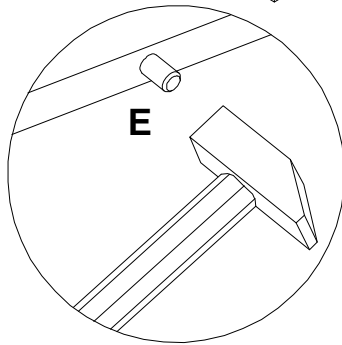
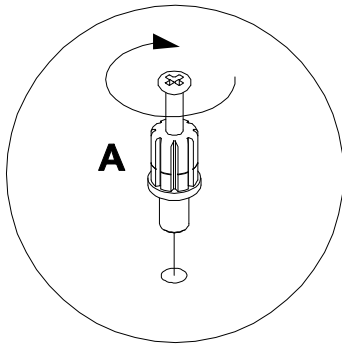
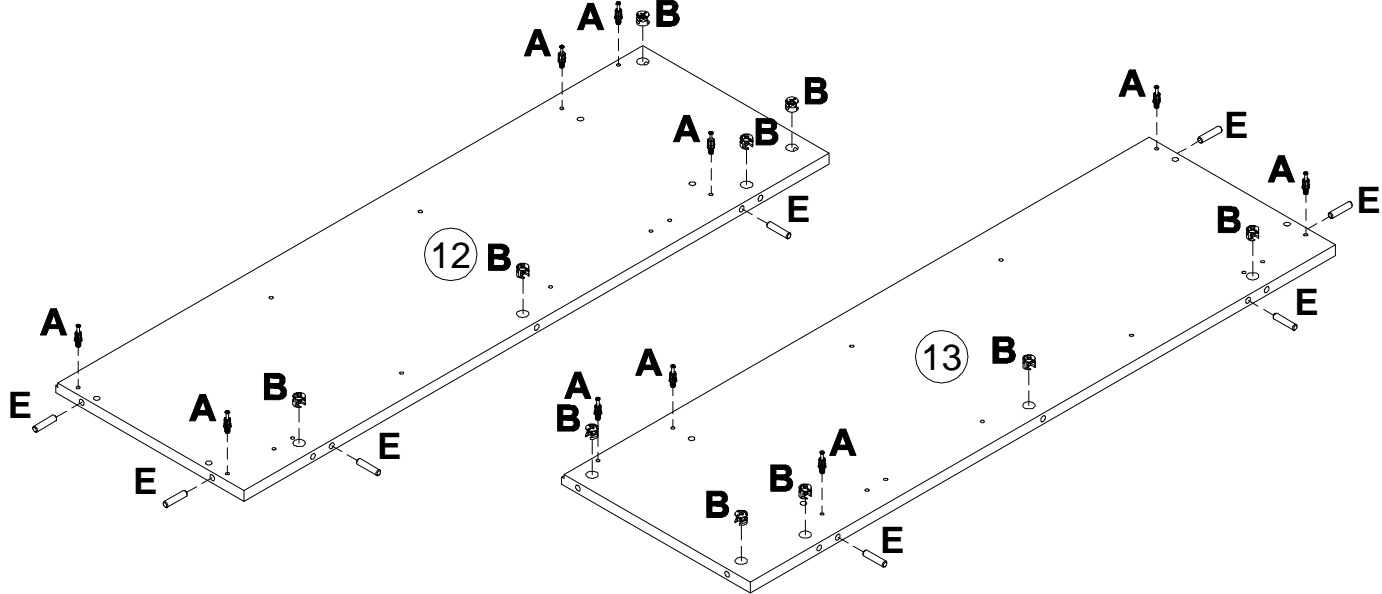
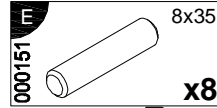
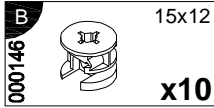
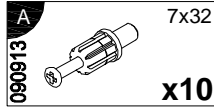

25

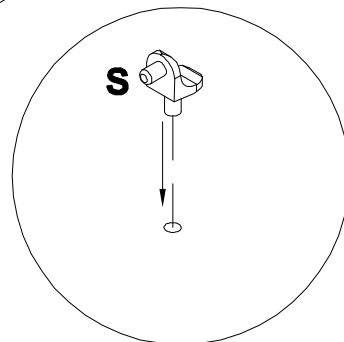
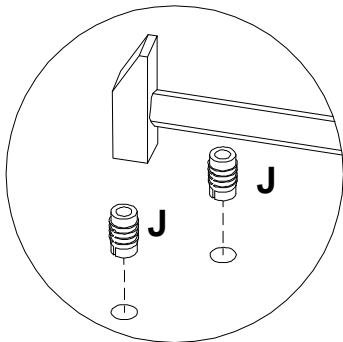
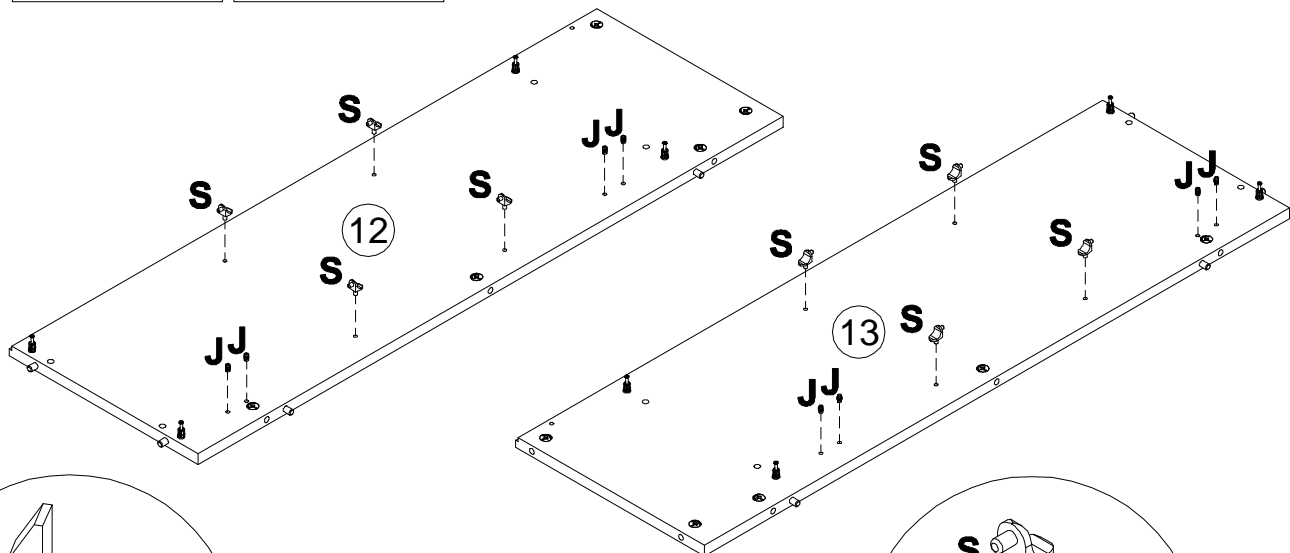
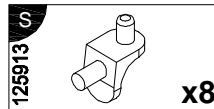
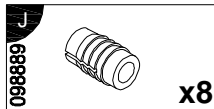

26

000146



15x12

x4

125913

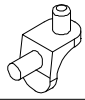

x4

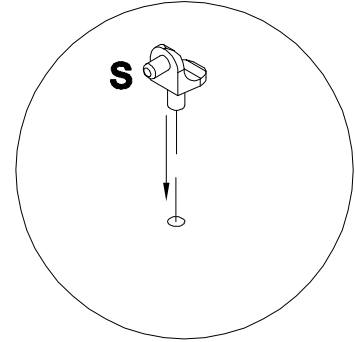
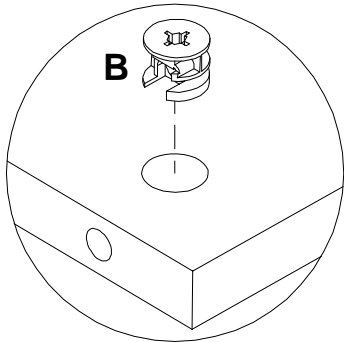
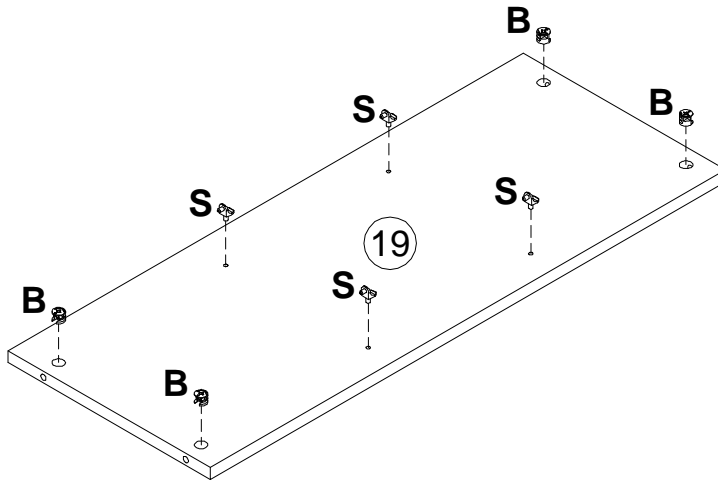

27

098889



x4

168983

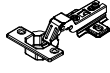

x2

010942



4x16

x4

125913



x4

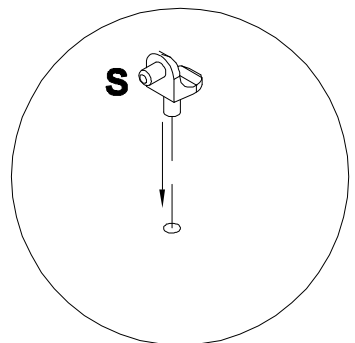
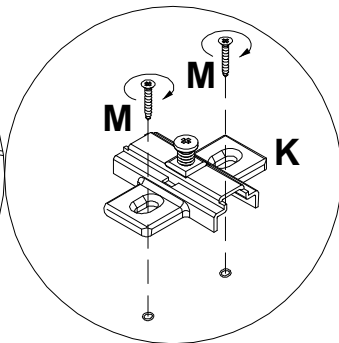
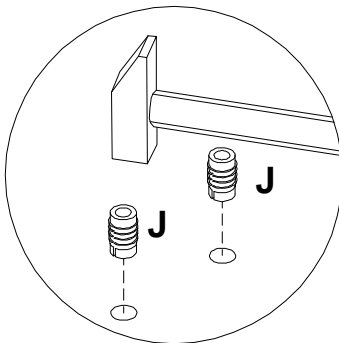
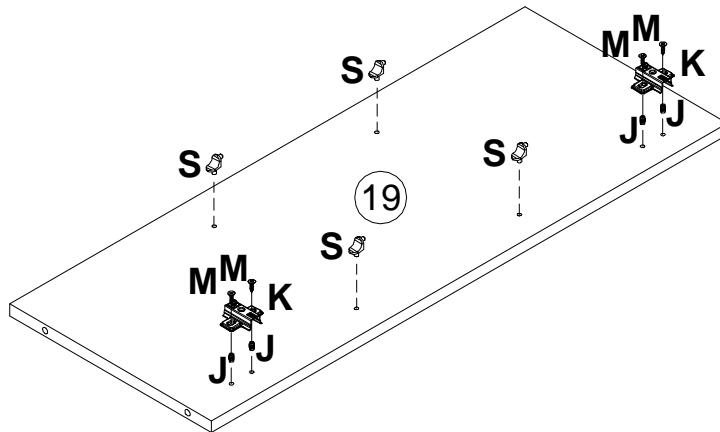

28

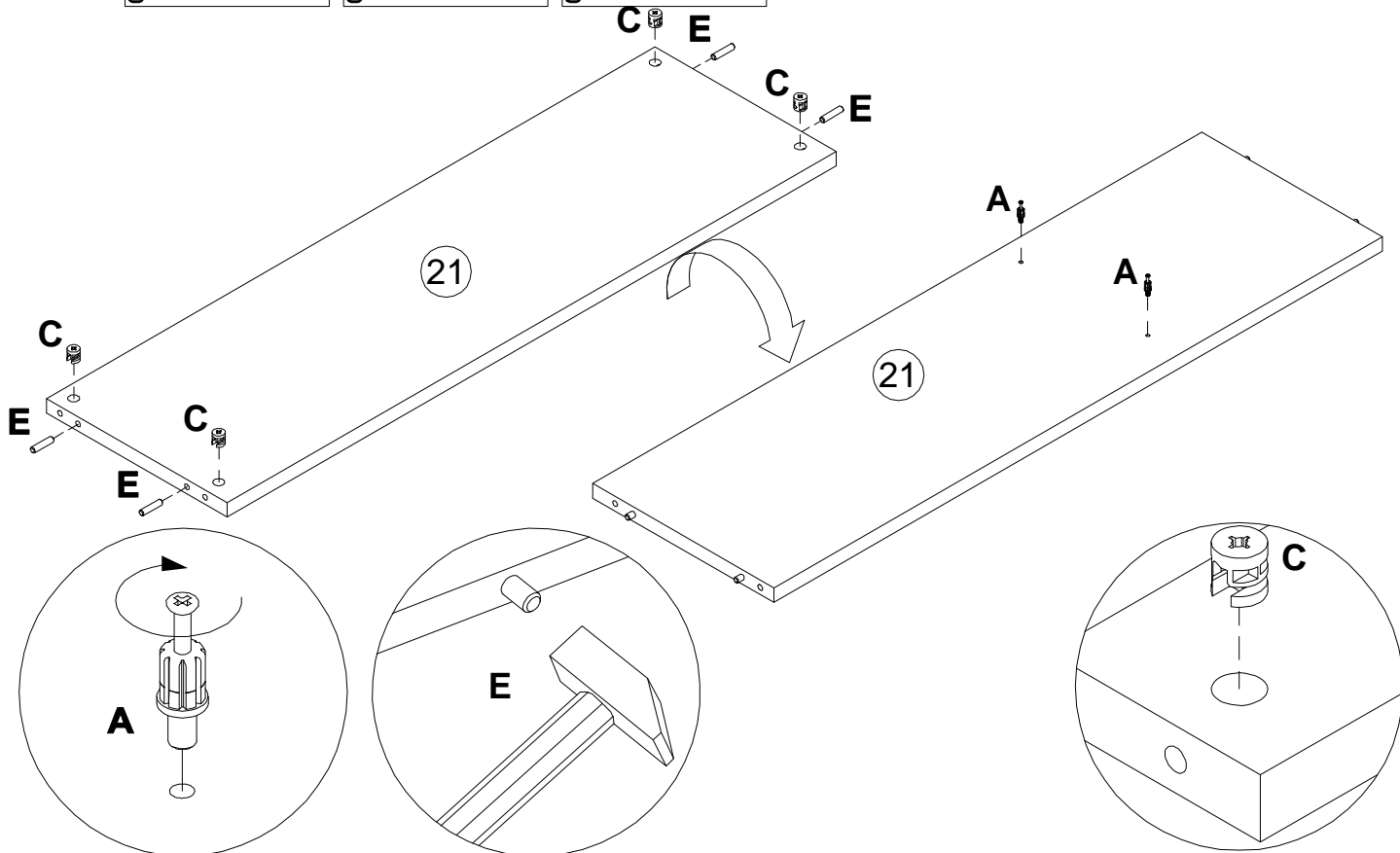
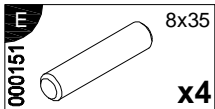
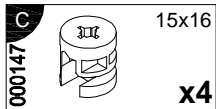
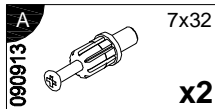

29

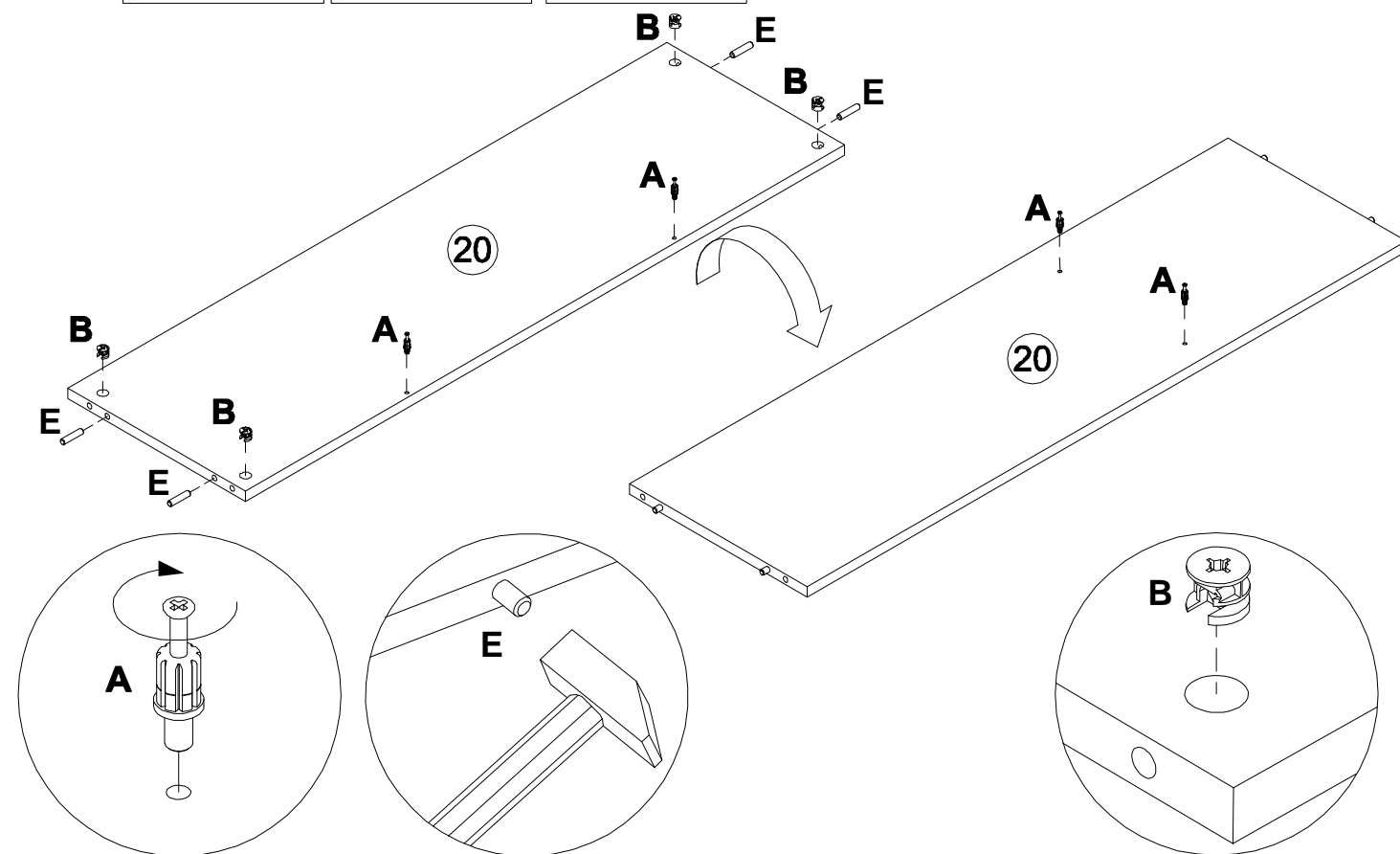
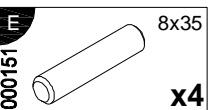
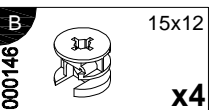
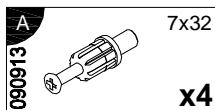

30 x2

090913

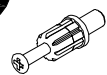

7x32

x6

000151

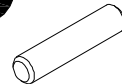

8x35

x4

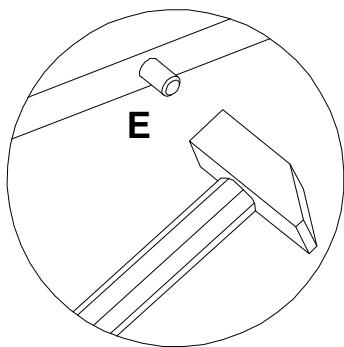
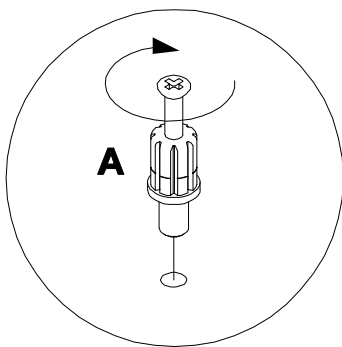
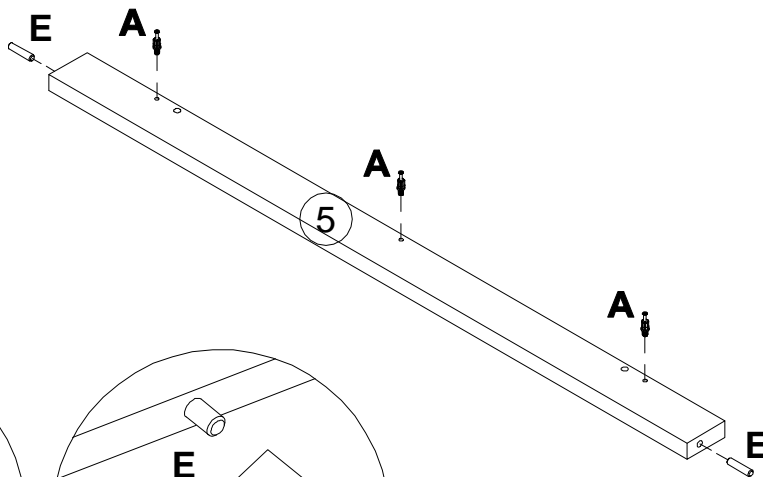

31

000146



15x12

x6

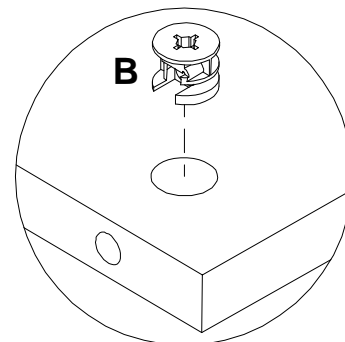
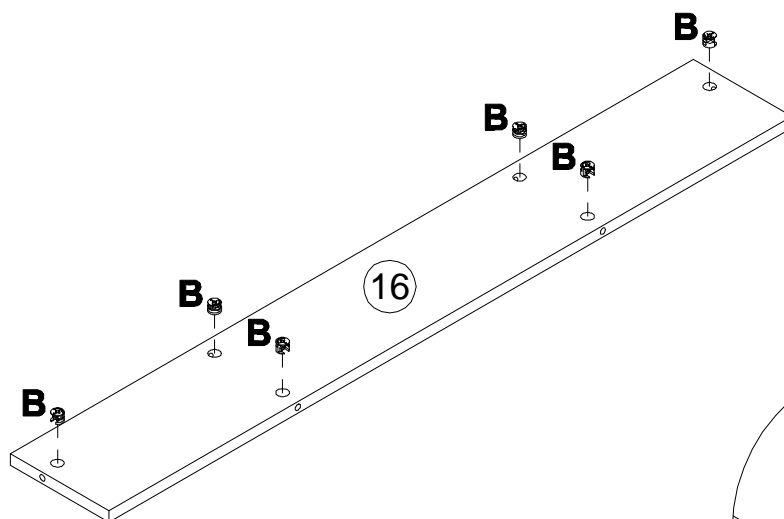

32

F 20x0.5
100640 x6

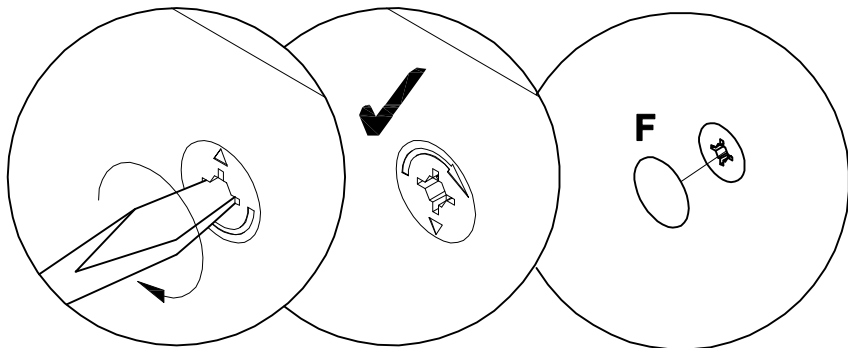
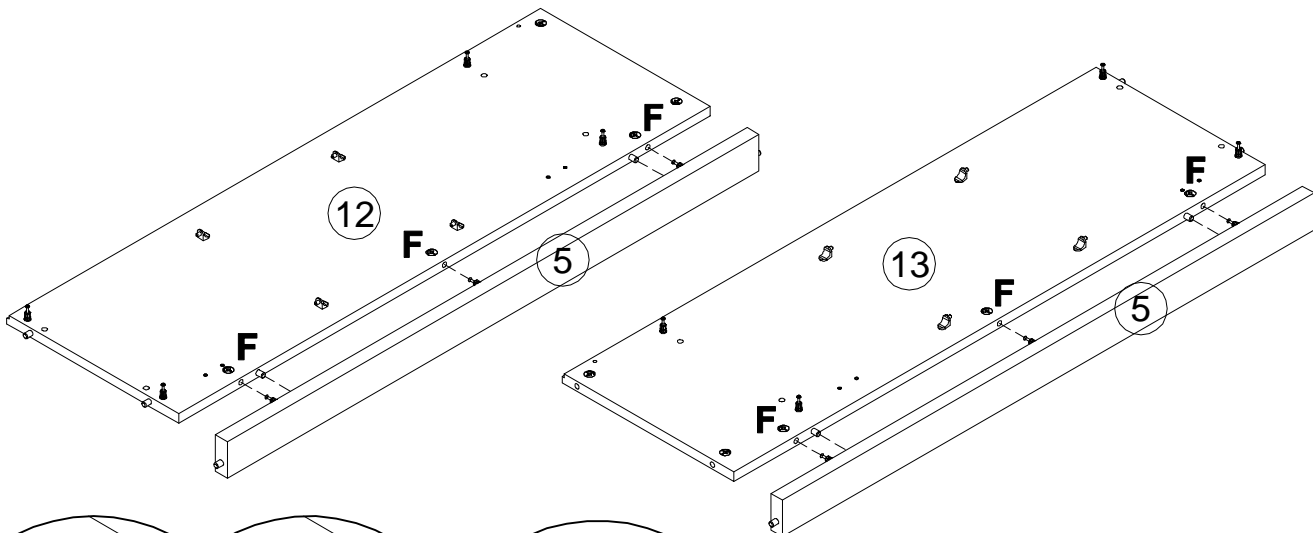

33

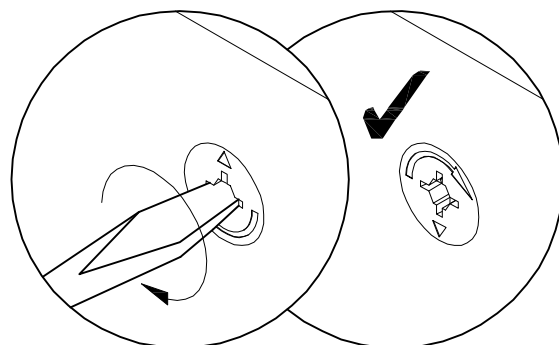
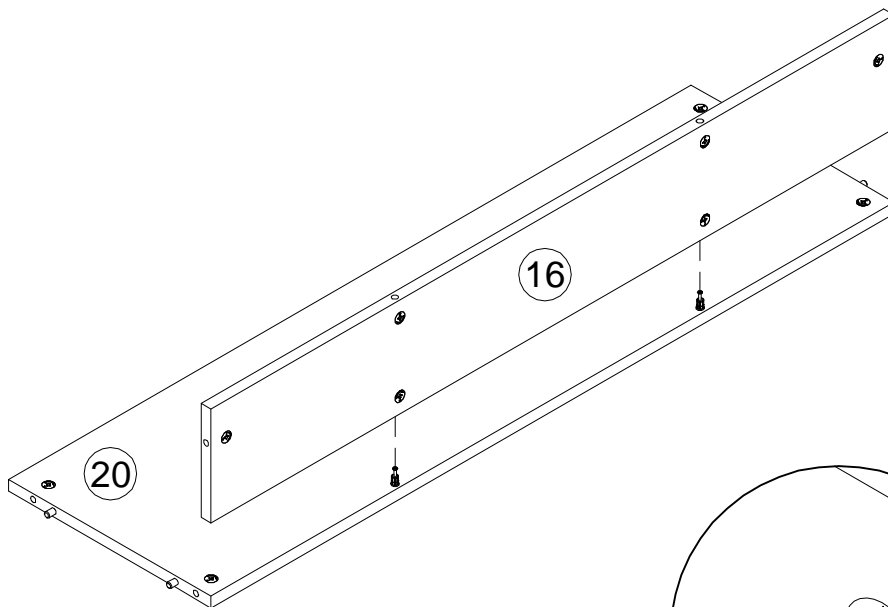

34

100640 F 20x0.5 x4

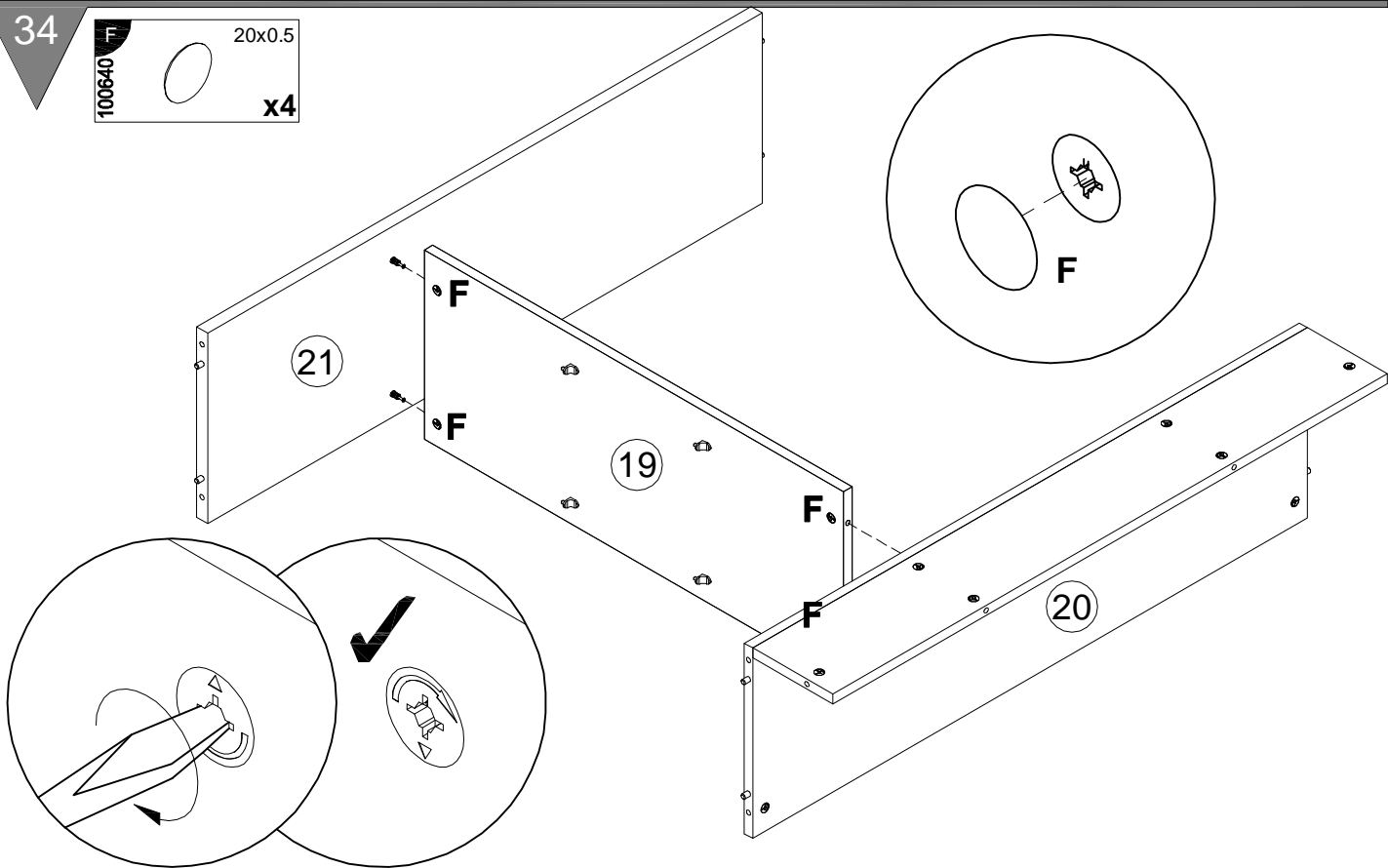

35

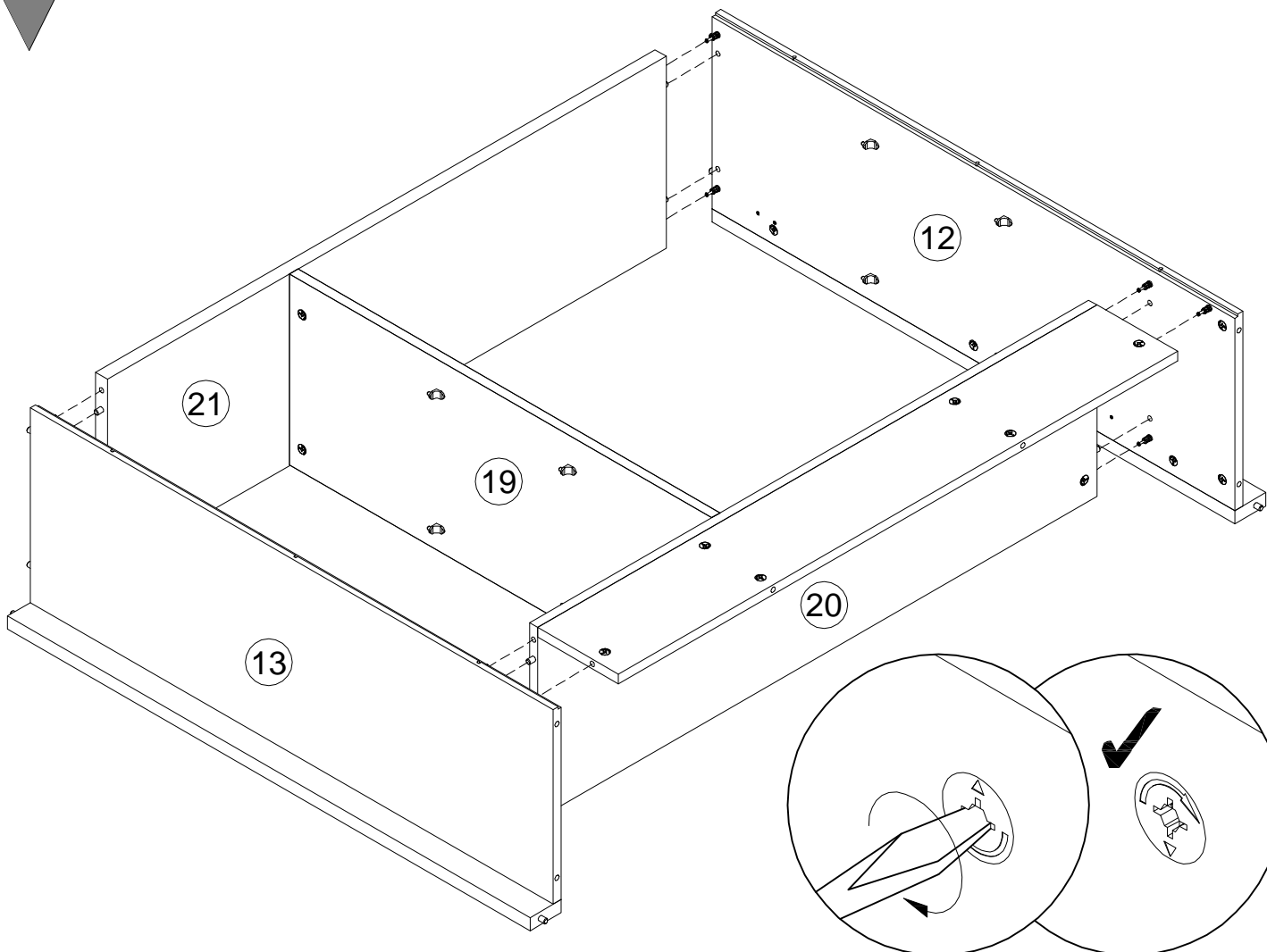

22

36

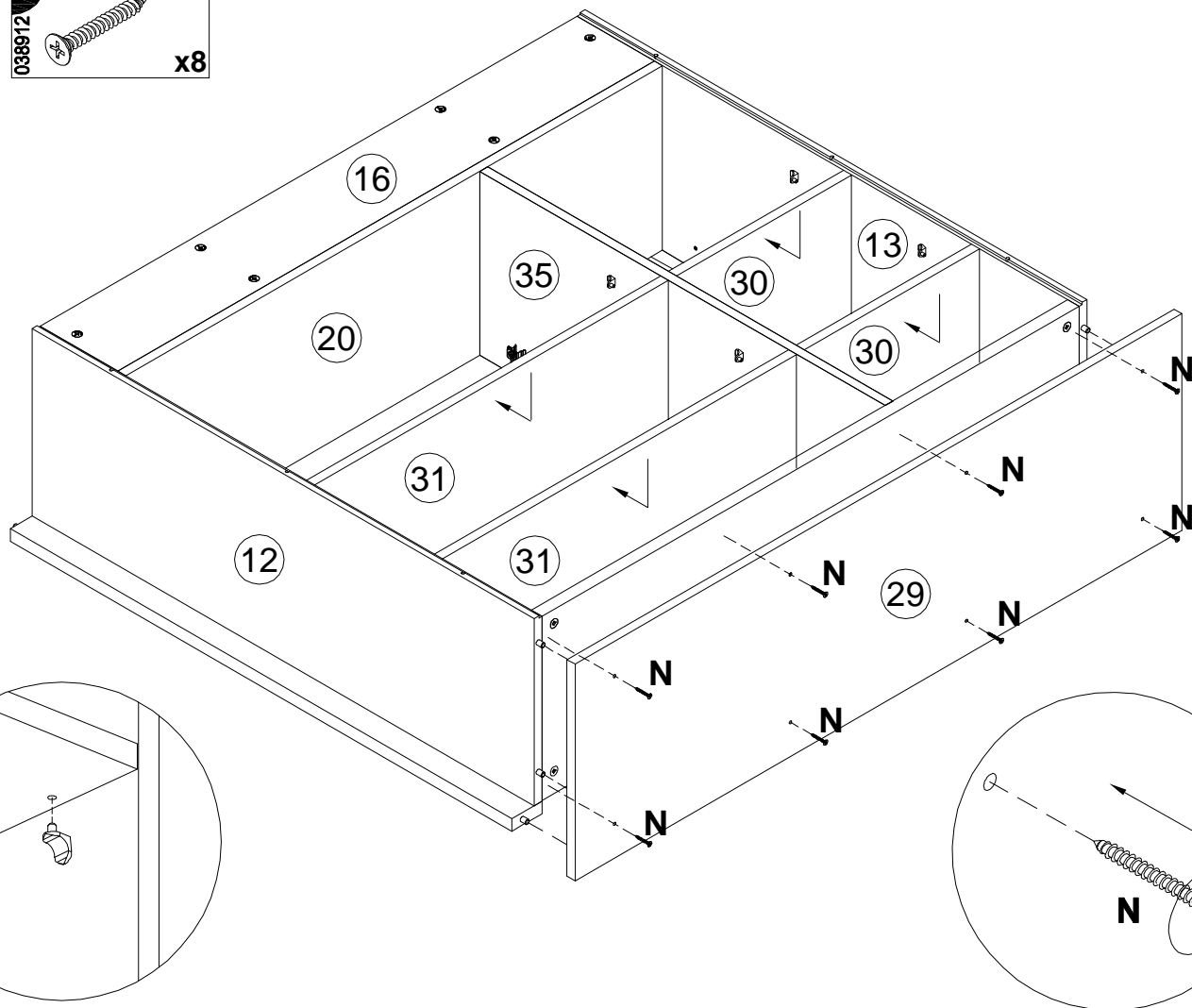
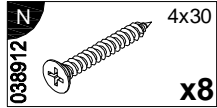

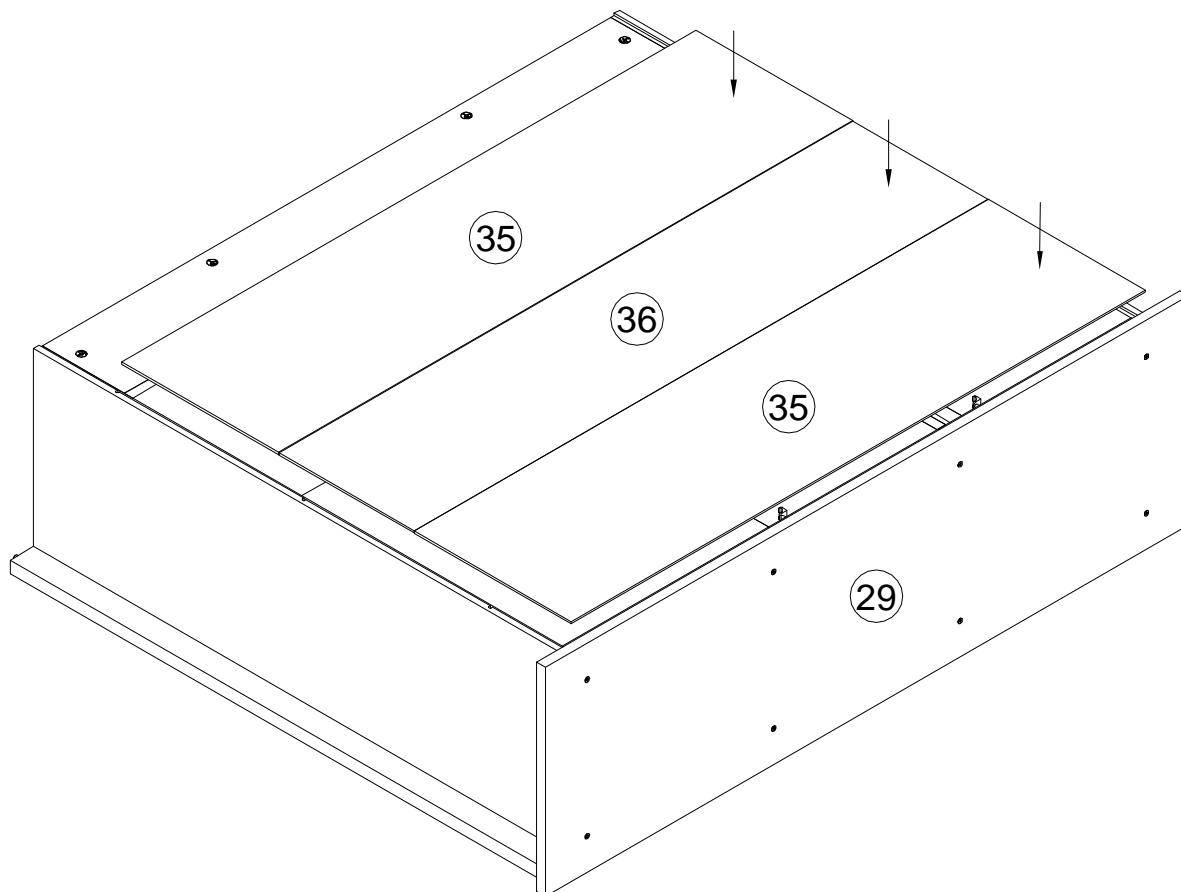

37

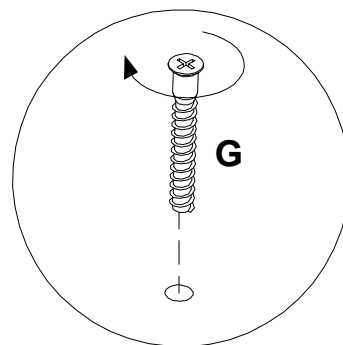
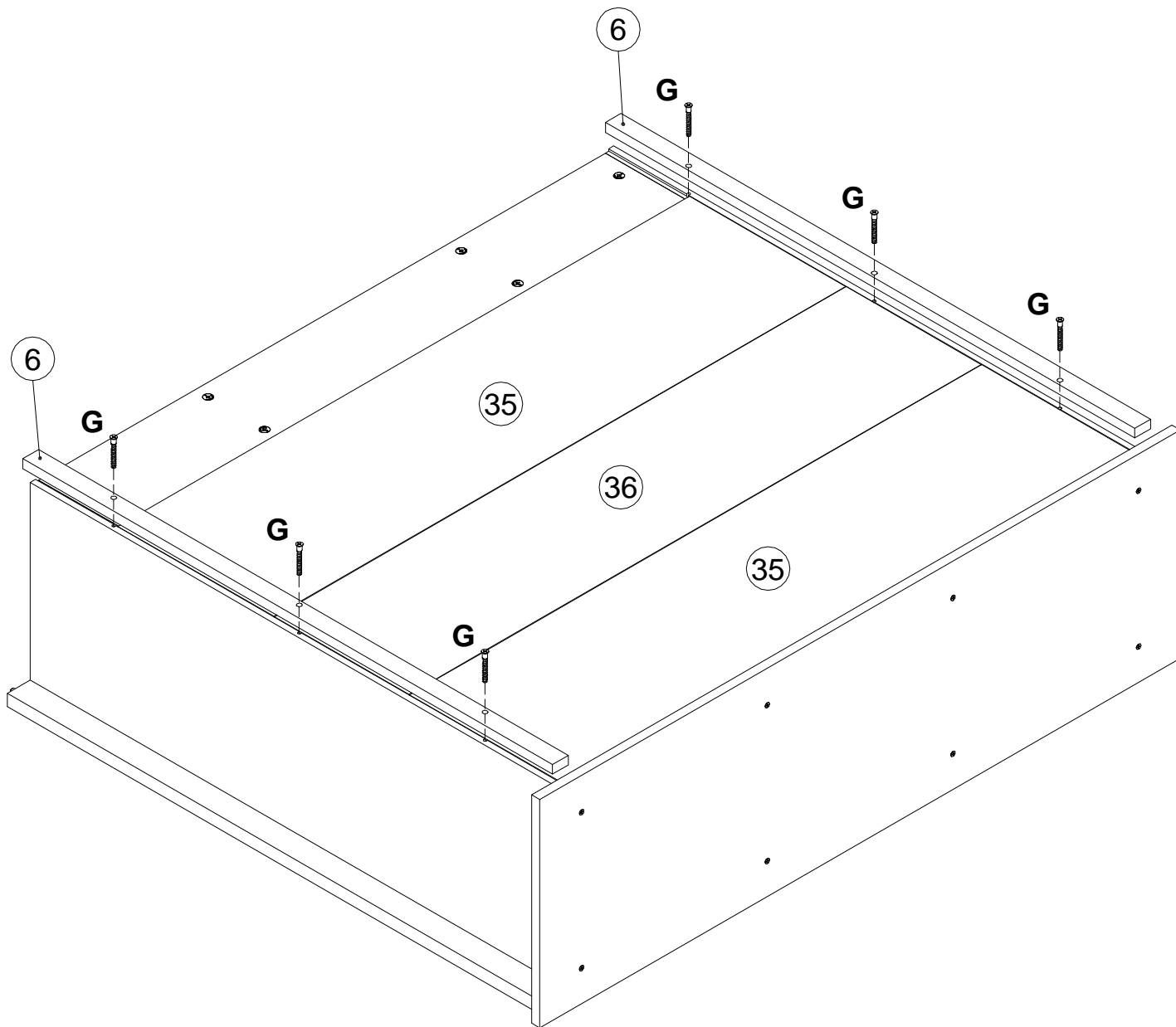
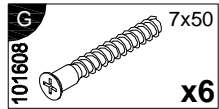

38

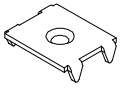

| | | | | | | | | | |
|-------------|---|-----|-------------|---|----|-------------|---|------|-----|
| 135021 T |  | x12 | 062367 U |  | x6 | 000759 V |  | 3x20 | x24 |
|-------------|---|-----|-------------|---|----|-------------|---|------|-----|

L1=L2

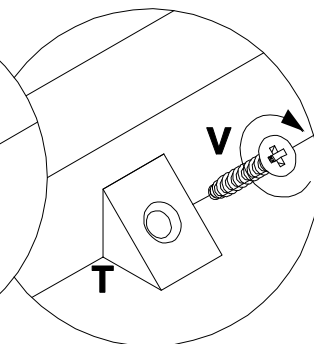
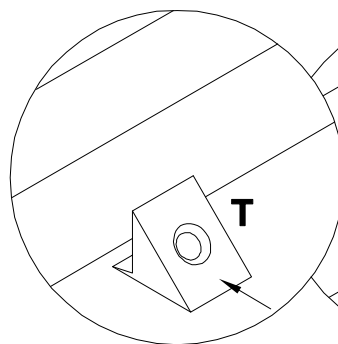
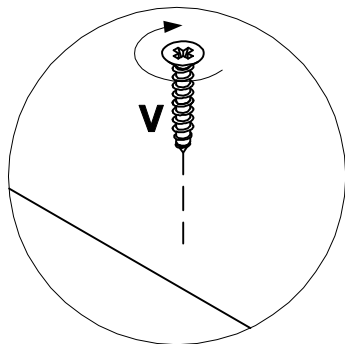
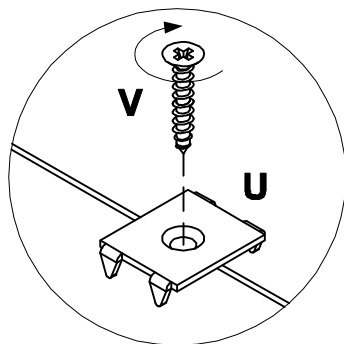
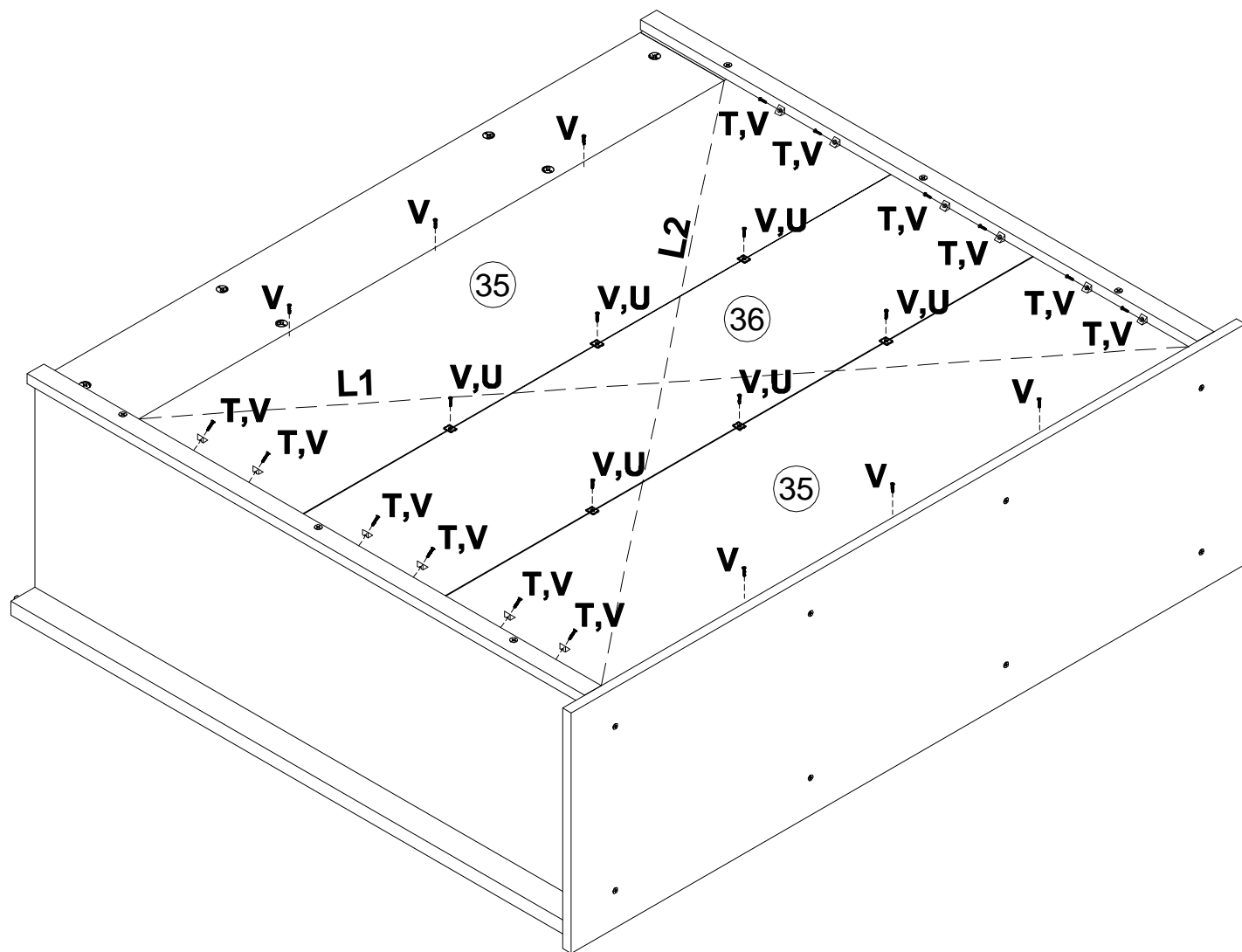

100640 F 20x0.5 x4

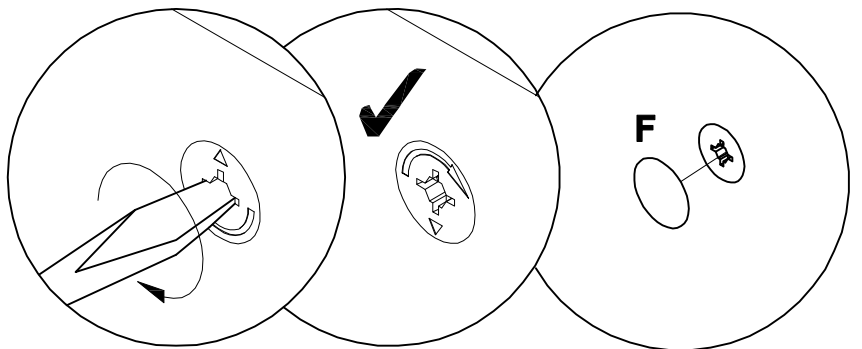
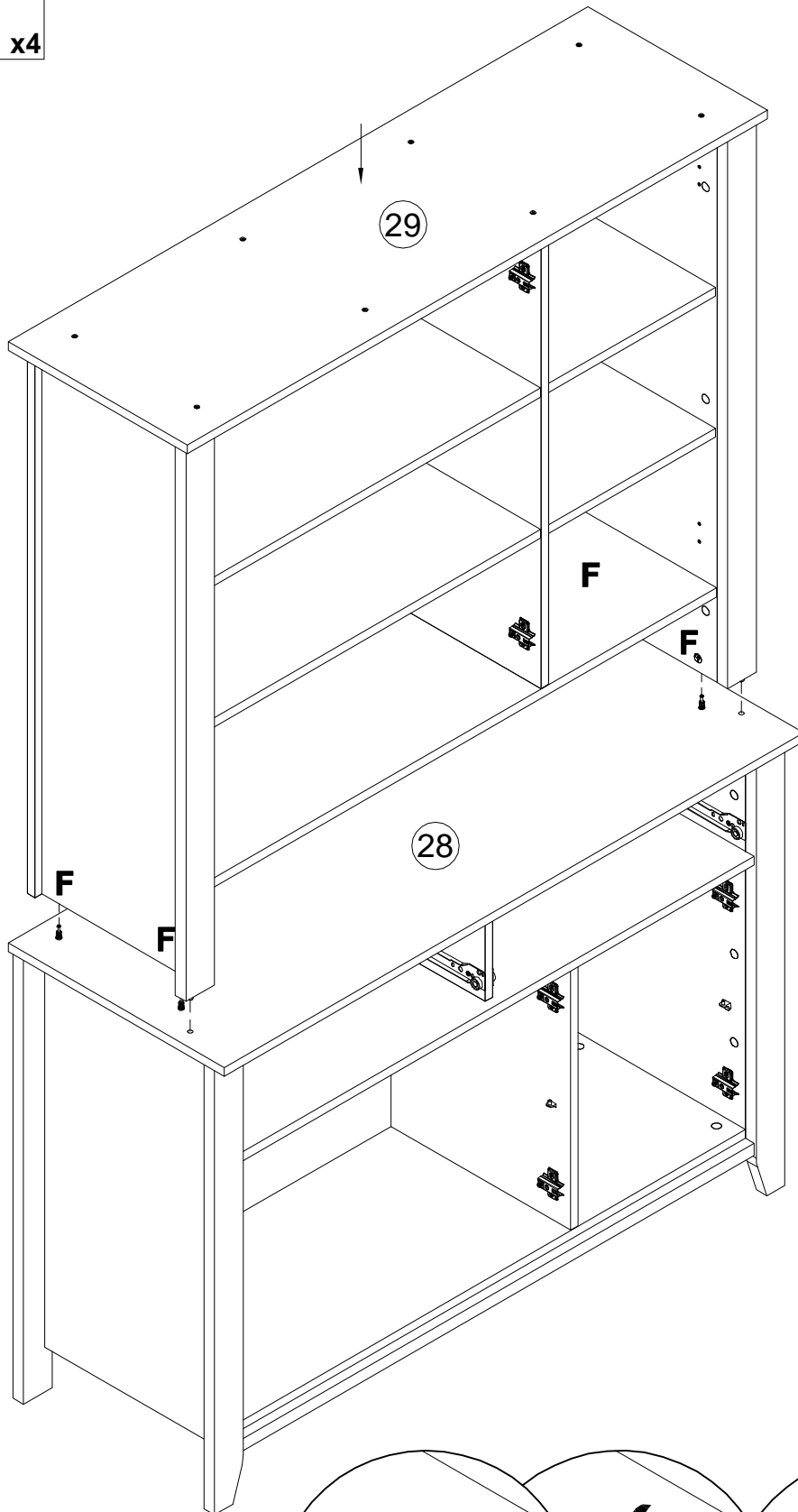

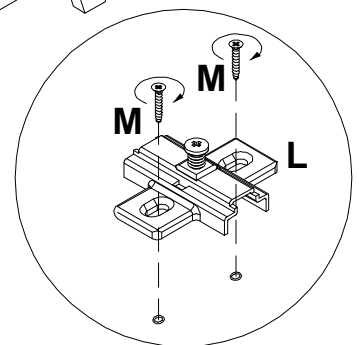
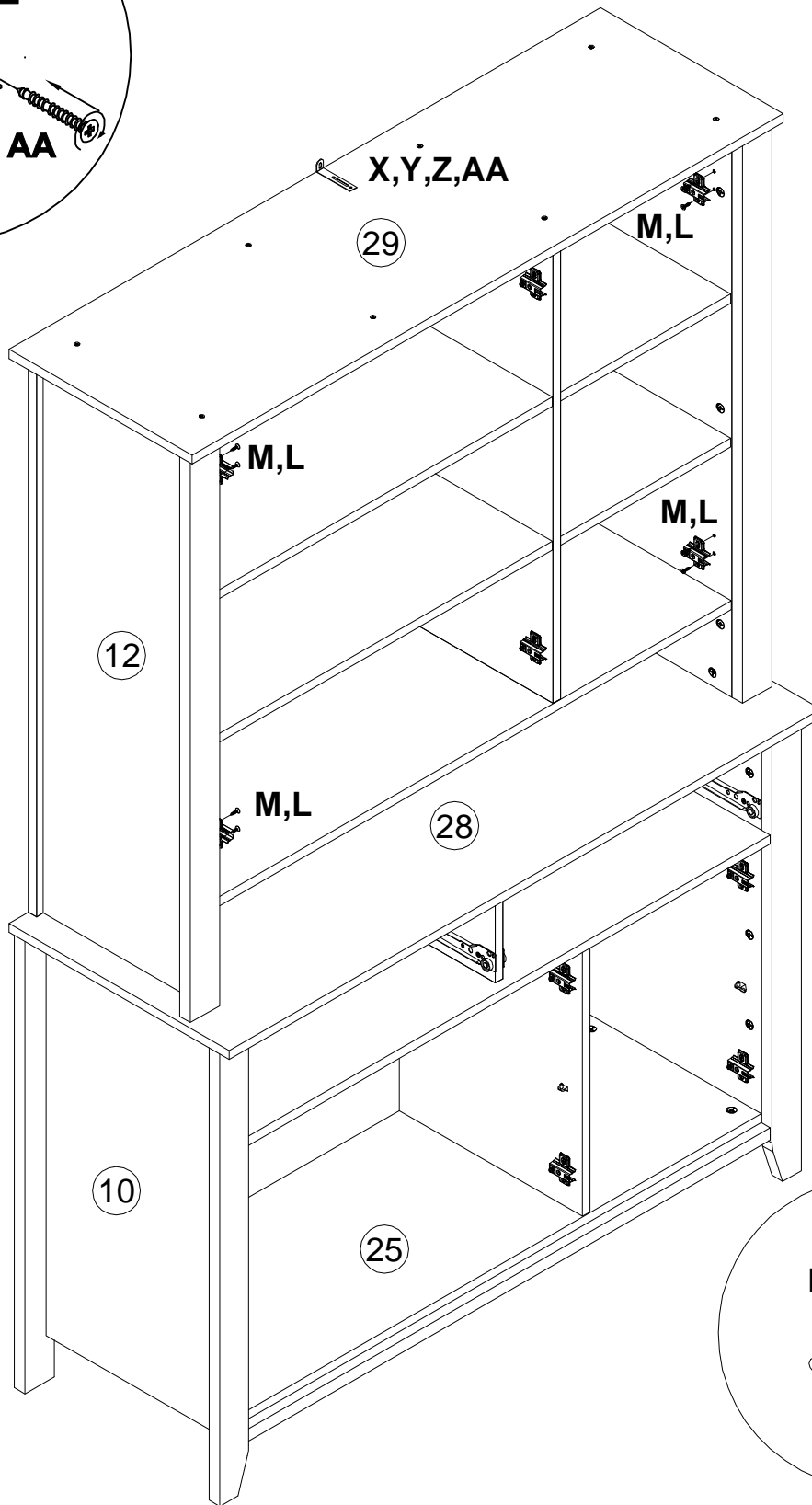
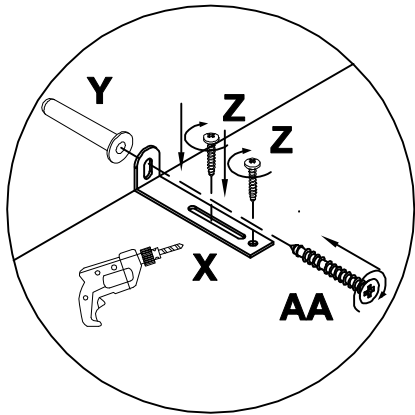
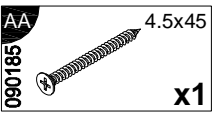
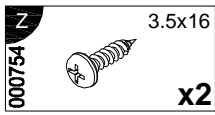
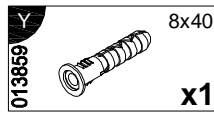
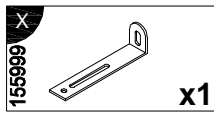
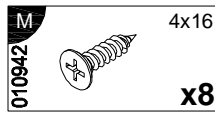
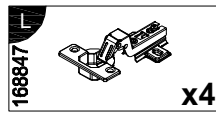

42 x2

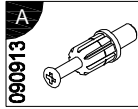

090913 7x32 x8

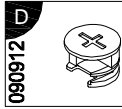

090912 15x10 x8

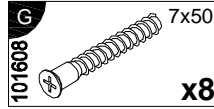



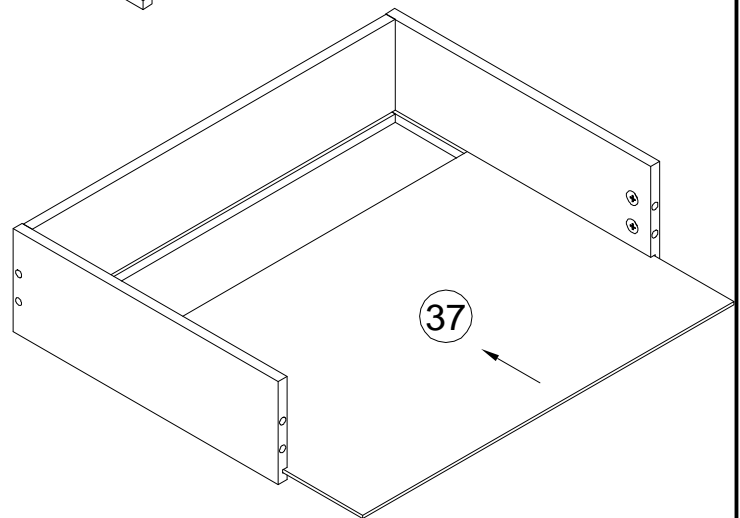
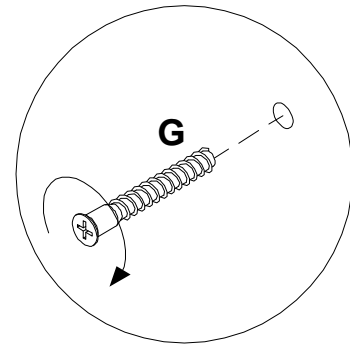
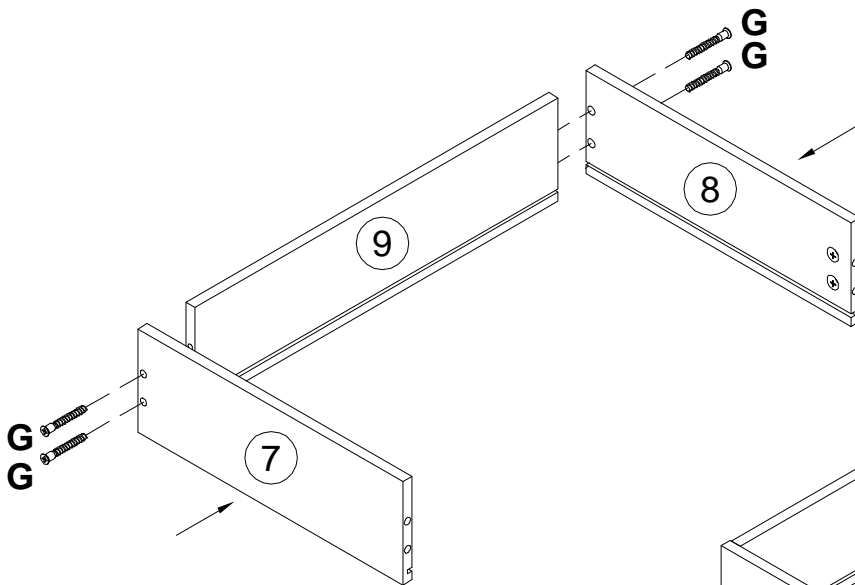
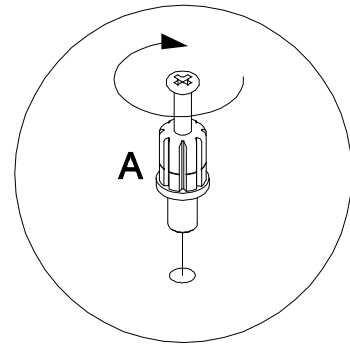
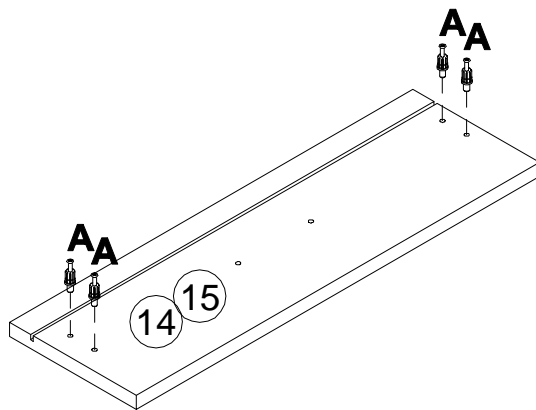
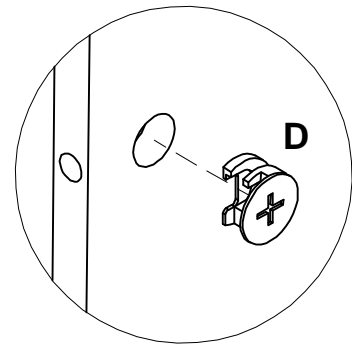
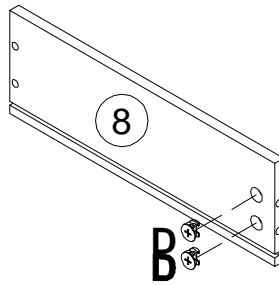
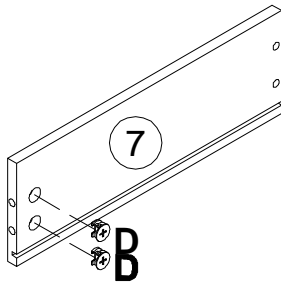

101608 7x50 x8

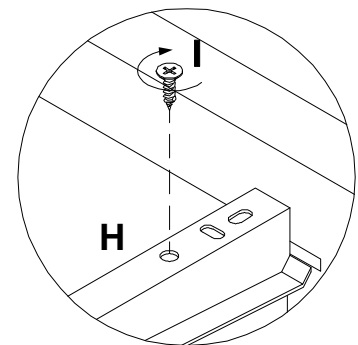
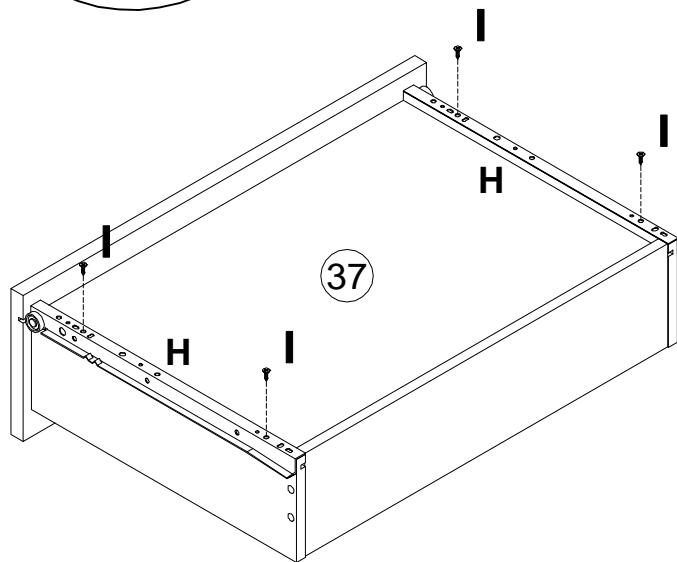
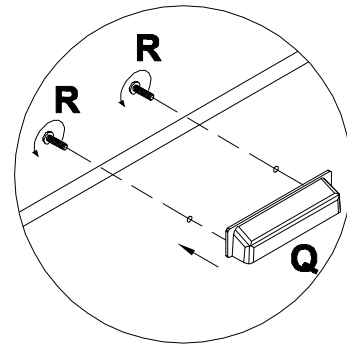
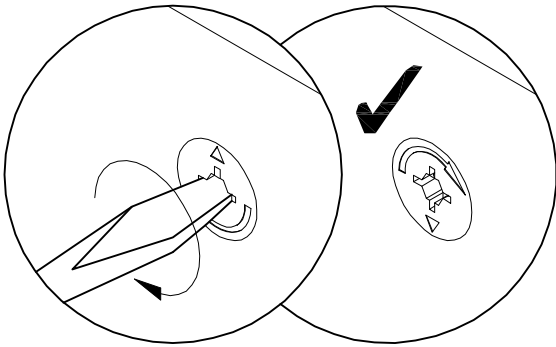
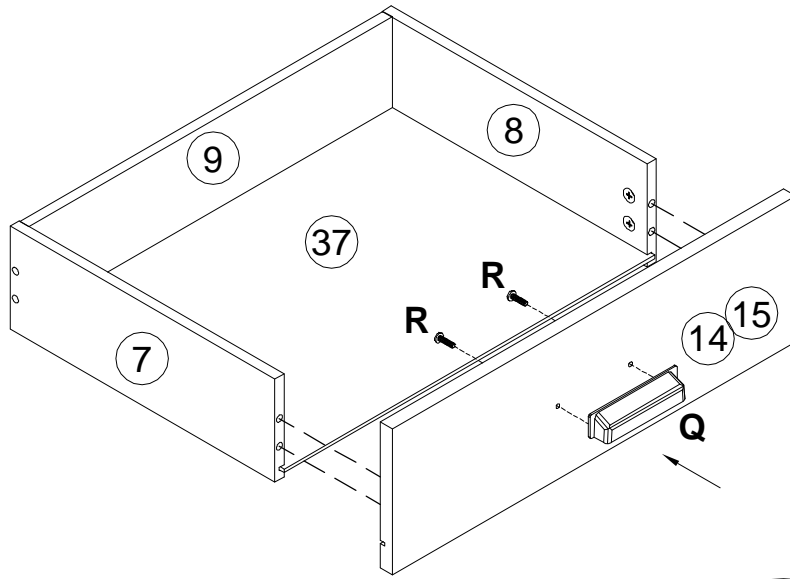
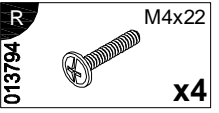
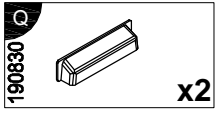
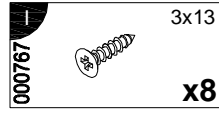
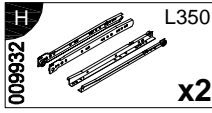

43 x2



| | | | | |
|---|---|---|---|---|
| <p>K 168983 x4</p>  | <p>L 168847 x8</p>  | <p>M 010942 4x16 x24</p>  | <p>P 189569 x6</p>  | <p>R 013794 M4x22 x6</p>  |
|---|---|---|---|---|

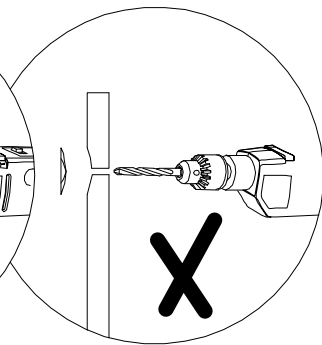
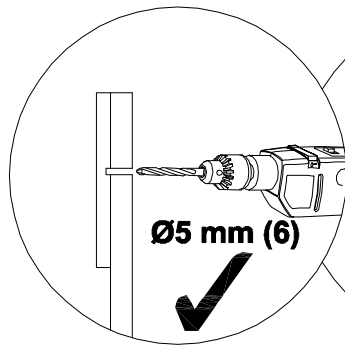
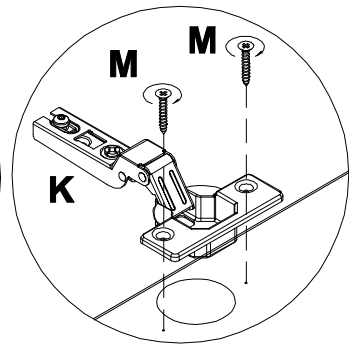
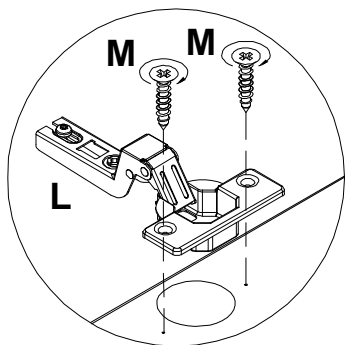
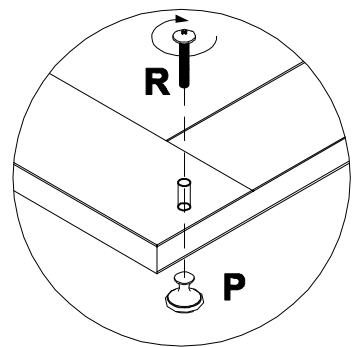
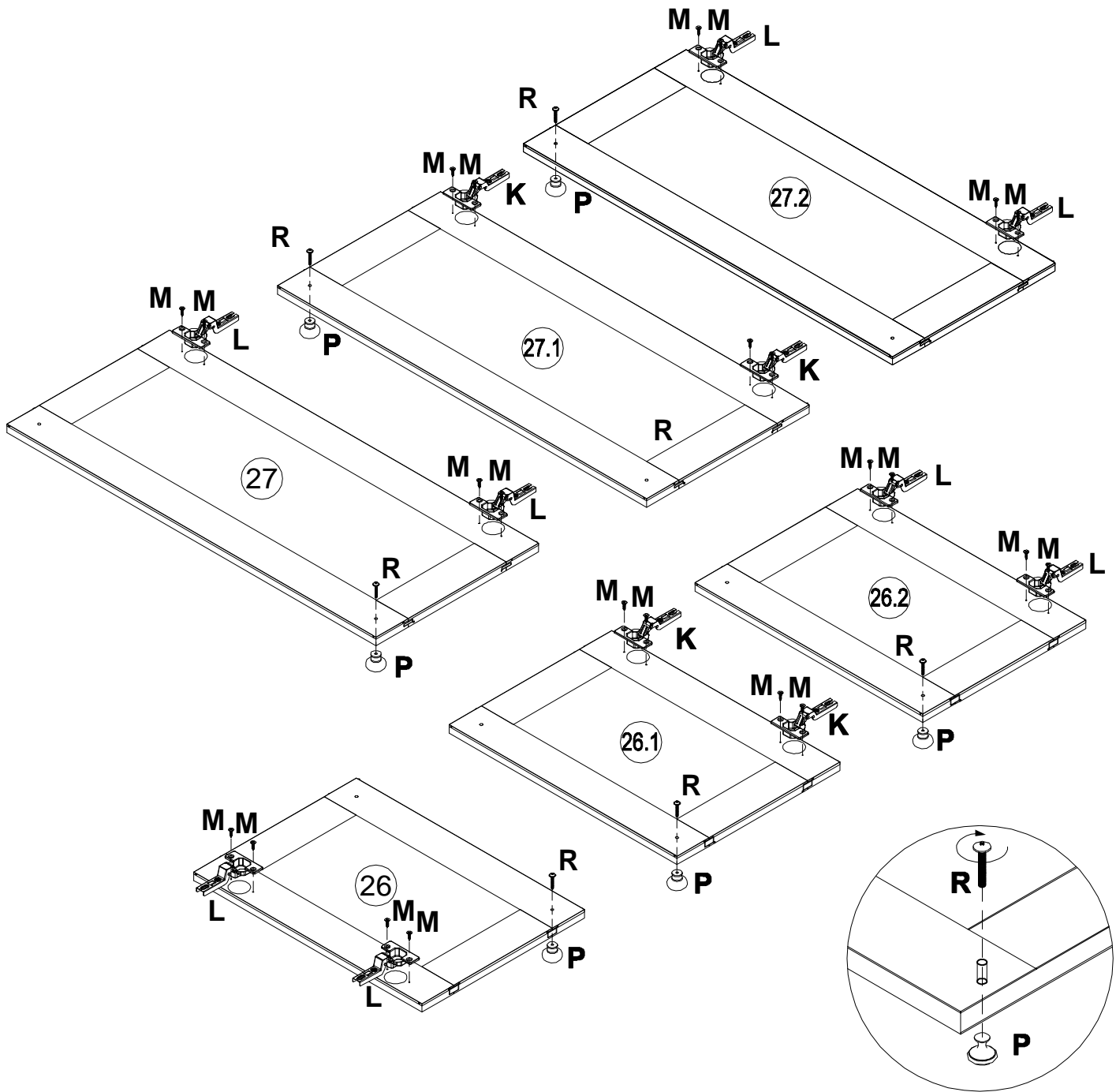

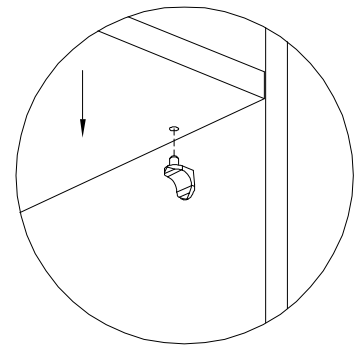
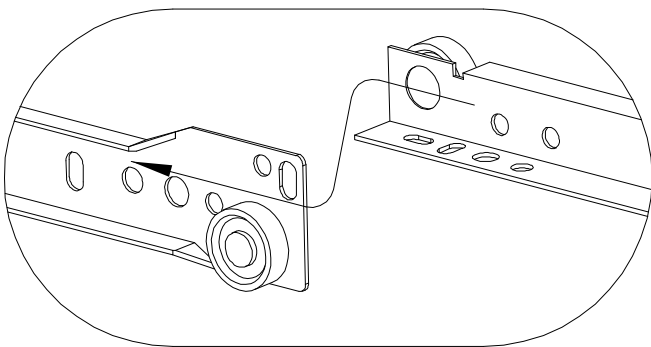
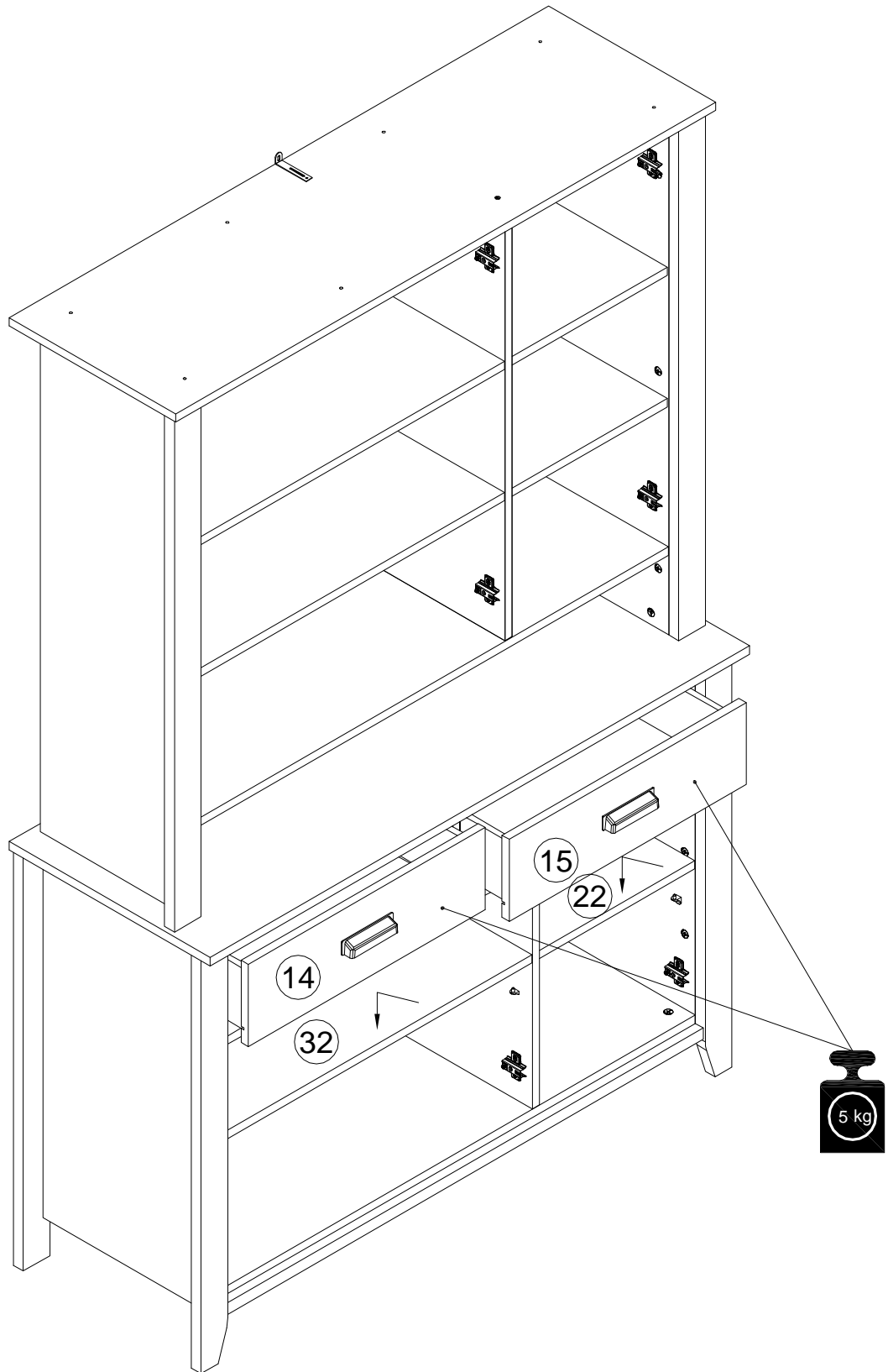

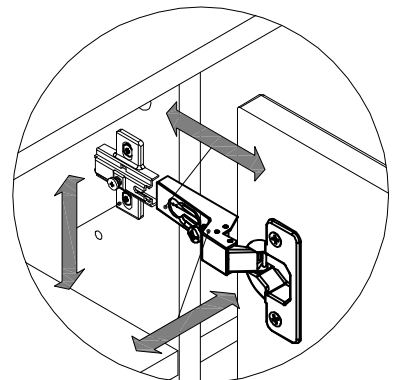
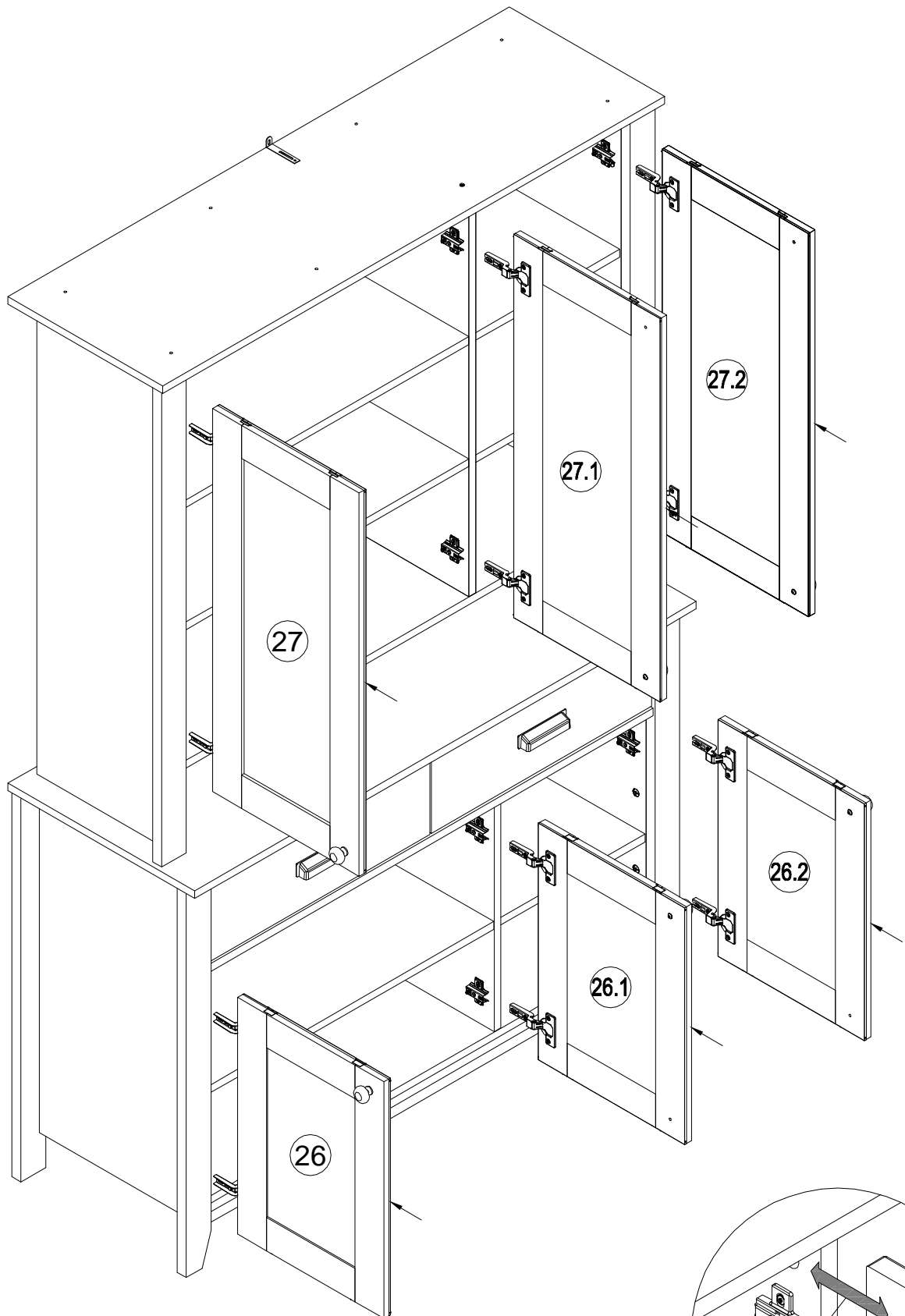



Achtung • Attention • Attenzione
Opgelet • Uwaga • Pozor • Figyelem
Atenție • Dikkat • Внимание



| | |
|------|---|
| (D) | Wandbefestigung dient als Kippschutz – unbedingt anbringen! Bei einigen Wandtypen kann ein Spezialdübel erforderlich sein! |
| (GB) | The wall fastening serves to prevent tipping – be absolutely sure to mount it! For certain wall types, a special wall plug may be necessary! |
| (FR) | La fixation murale sert de protection contre le basculement – à installer impérativement ! Pour certains types de murs il faut des chevilles spéciales ! |
| (IT) | Il fissaggio alla parete serve da protezione anti-ribaltamento – attaccarla assolutamente ! Per alcune strutture di parete può essere necessario un tassello speciale ! |
| (NL) | Bevestiging aan de muur dient als kantelbescherming – zeker en vast bevestigen ! Bij enkele muurtypes is een speciale plug misschien vereist ! |
| (PL) | Mocowanie do ściany jest jednocześnie zabezpieczeniem przed przewróceniem – koniecznie zamontować! Do niektórych rodzajów ścian koniecznie zastosować specjalne kołki mocujące. |
| (CZ) | Montáž na stěnu slouží jako ochrana proti převrhnutí – bezpodmienečně umístěte! U některých typů stěn může být zapotřebí speciální hmoždinka ! |
| (SK) | Upevnenie na stenu slúži ako ochrana proti prevráteniu – bezpodmienečne použite! Pre niektoré druhy stien môže byť potrebná špeciálna hmoždenka ! |
| (HU) | A termék a falhoz kel rögzíteni, különben az felborulhat! Egyes fal típusoknál speciális tiplit kell használni ! |
| (RO) | Sistemul de fixare la perete serve ște ca protecție la răsturnare – de montat obligatoriu! Pentru unele tipuri de pereți este posibil să fie necesar un diblu special ! |
| (TR) | Duvardaki sabitleme, devrilmeye kar ş› bir emniyet tedbiridir ve mutlaka monte edilmelidir! Baz › duvar tiplerende bunun için özel bir düble gerekli olabilir ! |
| (RU) | Обязательно установите крепление на стене во избежание опрокидывания ! Для некоторых типов стен может потребоваться специальный дюбель ! |